



ACCESSIBILITY ON PUBLIC RIGHTS OF WAY AND COUNCIL LAND IN WIGAN

GUIDANCE NOTES

August 2017.

CONTENTS:

1.0	Introduction	3
2.0	Background	3
3.0	Access Controls	4
4.0	Decision process for installing and improving barriers	7
5.0	Gaps, Surfacing & Gradients	9
	Path Surface	9
	Path Width	9
	Gaps & Width Restrictions	9
	Ramps & Gradients	9
	Ramp Rise	9
	Cross Slope	9
	Steps & Kerbs	10
	Surface Gaps	10
	Clear Walking Tunnel	10
	Passing Places	10
	Resting Places	10
	Appendix One – Flow Chart and Pro-forma	11
	Appendix Two – Approved Specifications	16
	Chicane	18
	Two Way Self Closing Gate	19
	Easy Access Metal Swing Gate	20
	Horse Friendly Gate(Wide)	21
	Horse Friendly Gate(Narrow)	21
	Horse Friendly Gate with Wheelchair Accessibility	23
	Stock Proof Kissing Gate	24
	Optional Handle on Swing Gate	25
	Wooden Horse Stile	26
	Dog Gate	27

1.0 INTRODUCTION

Within the Borough of Wigan there are hundreds of access control points on 480km of public rights of way, in addition to those which are on public and private land. The aim of these guidance notes is three fold:

- To provide guidance on procedures to follow in authorising new and replacement barriers,
- To provide guidance on standards for improving and creating routes, and
- To provide examples of structures which have and are being trialled to benefit the effective management of land and public rights of way.

This document will be reviewed in line with new legislation, new designs and changing demands.

2.0 BACKGROUND

2.1 Accessibility on public rights of way and other permissive routes is an issue for disabled users, people with pushchairs or young children, the elderly and less able people, who may not necessarily be considered to have a disability. No assumptions can be made about the capabilities of disabled path users as disabilities are wide ranging and not always obvious; they can include mobility impairment, sensory impairment (e.g. sight or hearing problems) and learning difficulties. Approximately 20% of the UK population have a disability and only 5% of those are wheelchair users. The varying degree of ability and desire to experience challenge; means that disabled users can be expected to make use of any route open to the public.

2.2 The Equality Act 2010 incorporates the main objectives of the Disability Discrimination Acts of 1995 and 2005 and under Section 149: A public authority must, in the exercise of its functions have due regard to the need to:-

- Eliminate discrimination, harassment, victimisation and any other conduct that is prohibited by or under this Act;
- Advance equality of opportunity between persons who share a relevant protected characteristic and persons who do not share it;
- Foster good relations between persons who share a relevant protected characteristic and persons who do not share it.

The relevant protected characteristics are identified as:-

Age, disability, gender reassignment, pregnancy and maternity, race, religion or belief, sex, sexual orientation.

2.3 Most public rights of way recorded on the Definitive Map are maintainable at public expense, Under Section 41 of the Highways Act 1980; Duty to maintain highways maintainable at public expense, it clearly states that this duty lies with the local highway authority. However in Defra's ROW Circular (1/09) 'Guidance for Local Authorities' it states in paragraph 6.5 that 'Maintenance

need not conform to an arbitrary standard of construction or appearance, but it should harmonise with the general appearance and character of the surroundings.’ There is no expectation or desire to change the nature of routes to make them ‘easy access’. However the least restrictive option should always be sought when access controls are a consideration, having regard for what can be considered ‘reasonable’ in terms of the available resources, terrain, land use and character, plus the effect on all other user groups and landowners/occupiers.

- 2.4 Public rights of way are categorised as; footpaths, bridleways, restricted byways and byways open to traffic. In Wigan there are approximately 480km of public rights of way comprising approximately 440km of footpaths; for people on foot and 40km of bridleways for people on bicycle, horse and foot. It should be noted that people using a wheelchair or mobility scooter have a right of access on both public footpaths and bridleways.

3.0 ACCESS CONTROLS

- 3.1 Historically a gate or stile was installed on a public right of way for the benefit of the landowner/occupier, to enable them to enclose land and manage livestock. Therefore in the majority of instances it is the responsibility of the landowner to maintain any structure that is on a public right of way across their land. The Council has a duty to ensure that a public right of way is not obstructed by a structure that is in disrepair, or unauthorised. However; the Council cannot force a landowner/occupier to change an access control to one that is more accessible for users; e.g. a stile to a gate.

Access controls can only be authorised by the Council if it meets specific legal requirements set out in the Highways Act 1980:

- A highway authority may provide and maintain in a highway maintainable at the public expense by them which consists of a footpath or bridleway, such barriers, posts, rails or fences as they think necessary for the purpose of safeguarding persons using the highway.
- To place objects or structures on, in or over a highway for the purpose of:
 - (i) Enhancing the amenity of the highway and its immediate surroundings; or
 - (ii) Providing a service for the benefit of the public or a section of the public.
- Power to authorise erection of stiles, etc. on a footpath or bridleway that crosses agricultural land that it would be expedient to enhance management of that land and for preventing the ingress or egress of animals.

Careful consideration must be given to where issues of safety conflict with access for some disabled, evidence will need to be provided identifying the

extent of the risk and therefore justifying any more restrictive barriers on the route.

3.2 If a barrier is installed on a public right of way or other permissive route that inhibits the passage of any legitimate user, discrimination will have taken place. It is possible that a disabled person could seek redress in the courts under the provisions of the Equality Act 2010. Section 175A of the Highways Act 1980 places a duty on local authorities to have regard for the needs of blind and disabled people when carrying out works or erecting structures on a public right of way. Section 147(2) (a) places a further duty on local authorities to consider the needs of persons with mobility problems when authorising structures on public rights of way.

3.3 In light of this the following principles of least restrictive access will be followed when considering installing or reviewing barriers on public rights of way, as well as other routes on Council owned land in Wigan Borough. The basic preference is no barrier at all; however a hierarchy has been identified:

- Gap
- Bollard
- Chicane
- Gate
- Kissing Gate.

Stiles are no longer considered appropriate for public access, however private landowners can still insist on using them. The Council will work to get more appropriate structures in place if an access control is still required. It is acknowledged that many stiles exist on public rights of way, mainly for historical reasons of stock control. It is council policy that where these are on Council owned land they will be phased out as they fall into disrepair and are removed or replaced with more accessible structures:

- Where possible a gap will be the preferred option, presenting no restriction or inconvenience to legitimate path users.
- Where there is a desire to prevent or slow the flow of traffic on a route a chicane or bollard will be the preferred option. This will prevent access for motor vehicles and act as a deterrent to illegal motorbikes making the route less attractive to them whilst not excluding legitimate path users. If the route is a bridleway this would also act to slow down cyclists and horse riders using the route.
- Signs will be used as appropriate on site to inform users that motor vehicles are not permitted and how users of the route can log a complaint should they experience problems.
- Should a barrier be required a self-closing gate with an easy-latch will be the preferred option. Where stock control is an issue a stock proof kissing gate may be appropriate, which will make routes less attractive for illegal motor vehicle users, whilst allowing access for most legitimate path users.

Mobility scooters may be too large for such structures as their length is comparable to that of some livestock.

- Where significant evidence exists in the form of reported incidents to the Police or Council and safety is an issue, more restrictive barriers against motor vehicles and nuisance will be considered. However these may inhibit access for some legitimate users.
- Any barriers installed will comply with the principles of 'British Standard 5709: Gaps, Gates and Stiles' as a minimum. However where possible the Council would seek to install more inclusive barriers in consultation with all users including disabled. Those barriers that have been successfully trialled are included as an appendix to this policy.
- Where a new structure abuts a vehicular road efforts should be made for the structure to be set back at least 4 metres from the carriageway for bridleways; and at least 2 metres for footpaths to allow users to traverse the structure without risk of being struck by vehicles. For footpaths likely to be used by groups of walkers and in all cases where a footpath directly crosses a road (i.e. to another path), the structure should be set back 4 metres. (BS 5709:2006, 4.1.6)

The Council will continually review and monitor this policy as new issues and guidance arise.

- 3.4 Whilst the Council will endeavour to follow this guidance on public rights of way, and certainly on Council owned land, it should be noted that where public rights of way cross privately owned land the landowners permission will need to be sought in order to change an existing barrier. The Council has no powers to enforce this, only to ensure that any barriers that exist are in a good state of repair and do not cause an obstruction to a public highway. If there is an obstruction then the Council will be under a duty to take enforcement action.
- 3.5 In all cases the least restrictive option possible will be sought, i.e. no barrier. The specifications detailed in the appendix comply with the principles of the 'British Standard 5709: Gaps, Gates & Stiles' and have been approved for disabled access by local user groups.

4. DECISION PROCESS FOR INSTALLING AND IMPROVING BARRIERS

4.1 Whilst the Council aspires for all barriers to comply with this guidance it is not practical for all existing barriers, over 700 on public rights of way alone, to be dealt with in the short term. However the process set out here will be applied when considering requests for new barriers and when looking at making changes to existing structures. In this way and by taking advantage of all opportunities that present themselves, assessment and subsequent improvement of barriers will have the cumulative effect of extending the accessibility of the network to all legitimate users over time. By looking at routes strategically it will be possible to work towards improving access on connected sections as a priority.

- In areas where a problem with fly tipping or illegal motor vehicle activity has happened or is perceived, an investigation should be carried out on the route and considered alongside evidence of the extent of the problem in the form of specific complaints that have been logged with the Environmental Crime Unit, the Police or the PROW and Neighbourhood Teams.
- When considering possible solutions it is preferable to work with the Police and Council Officers in line with Council Policies to address the source of the problem; installation of barriers should be a last resort.
- Where alternative measures have not reduced the problem consideration will be given to the possible installation of barriers. The extent of any discrimination such barriers will cause should be clearly identified and weighed against; the severity of the risk caused by the level of illegal motor vehicle use, or other nuisance to users of the network and the legal obligations of the Council.
- Where barriers are installed that restrict some disabled users they should be installed strategically. Avoid creating a situation where a disabled user can travel along a route only to find they can't access the other end, causing them to take a lengthy detour or back track their previous route. There can be benefits in restricting access at one access point to prevent use by motor vehicles as a through-route, whilst leaving alternative access points unrestricted to allow access to a particular destination such as a beauty spot or other facility.
- Where barriers are installed that restrict legitimate users they should be reviewed periodically. When the initial reason for installing the barrier is no longer present (such as stock control) or the problem of illegal motor vehicle use or other nuisance may have dissipated, consideration should be given to removing the barrier or replacing it with a less restrictive barrier. In this scenario consultation with the landowners, local councillors and residents should be considered where appropriate.

4.2 The flow charts and a pro-forma in Appendix One provide a guide for recording the decision-making process according to the principles outlined above. This

will be followed in all cases when considering the installation of barriers on public rights of way and other routes on Council owned land and will act as a disability equality impact assessment on the structure.

5.0 GAPS, SURFACING & GRADIENTS

5.1 The thirteen standards listed below (as identified by the Fieldfare Trust) should be used as a guide when improving or creating new routes. It will not be possible to meet these standards on all routes for reasons outlined in section 1 of this document, however they should be met as far as is reasonably possible. These standards apply to all users, the Fieldfare Trust does not define people or their abilities, by implementing such standards, access will be improved for everyone, including those with disabilities. There are no set standards that apply on public rights of way and it is recognised that the character and variety of routes should be kept, however where possible barriers should be avoided but if they are deemed necessary then the least restrictive should be the first option.

- a) **Path Surface** Surface should be compact some loose material is acceptable (stones no bigger than 10mm) but should not cover the entire surface.
- b) **Path Width** 1500mm minimum for a public footpath.
3000mm minimum for a public bridleway.
Permissive paths may be narrower with passing places.
- c) **Gaps and Width Restrictions** 815mm minimum width for no more than 300mm length.
915mm width for no more than 1600mm length.
Restrictions of less than 1100mm could still present a barrier to guide dog users.
- d) **Barriers** See above.
- e) **Ramps & Gradients** 1:20 maximum slope gradient.
1:12 maximum ramp gradient except in rural/working landscapes where the maximum ramp gradient can be 1:10 in exceptional circumstances.
- f) **Ramp rise** Where the gradient of a ramp is greater than 1:20 a level resting place or landing of at least 2.9m length should be provided. The maximum rise between landings is 950mm.

Maximum distance between landings for 950mm vertical climb at the following gradients.	1:18	17.10 metres
	1:16	15.20 metres
	1:14	13.30 metres
	1:12	11.40 metres
	1:10	9.50 metres

g)	Cross Slope	1:50 maximum.
----	--------------------	---------------

h)	Steps & Kerbs	150mm maximum step/kerb height for wheelchair access. 165mm maximum step height for pedestrian steps.
i)	Surface Gaps	Gaps in path surface structures such as boardwalks, grates, grills etc. should be no more than 12mm measured in the direction of travel along the path.
j)	Clear Walking Tunnel	A tunnel clear of overhanging / encroaching vegetation and other obstructions should be a minimum of 1500mm wide and 2100mm high for a footpath and 3000mm wide and 3700mm high for a bridleway.
k)	Passing Places	Where a section of path is less than 1500mm wide there should be a passing place every 50 to 150 metres along the path depending on the type of landscape. The minimum width of the passing place should be 1500mm for a 2000mm length.
l)	Resting Places	Providing a resting point approximately every 300 metres along a path can enable less able people to make greater use of the path network. A resting point can consist of a seat or perch placed on level ground on an area of 1200 x 1500mm to the side of the path. It may not always be possible to provide resting places and it is not a requirement on public rights of way, however they should be given consideration on Council owned land.
m)	Handrails	A handrail should be provided to help people negotiate height variation and for safety reasons. A rail should be constructed of galvanised steel with closed ends at the top and bottom. The rail should be extended by 300mm beyond the top and bottom of the ramp or stairs.

Appendix One
Flow Chart and Pro-forma

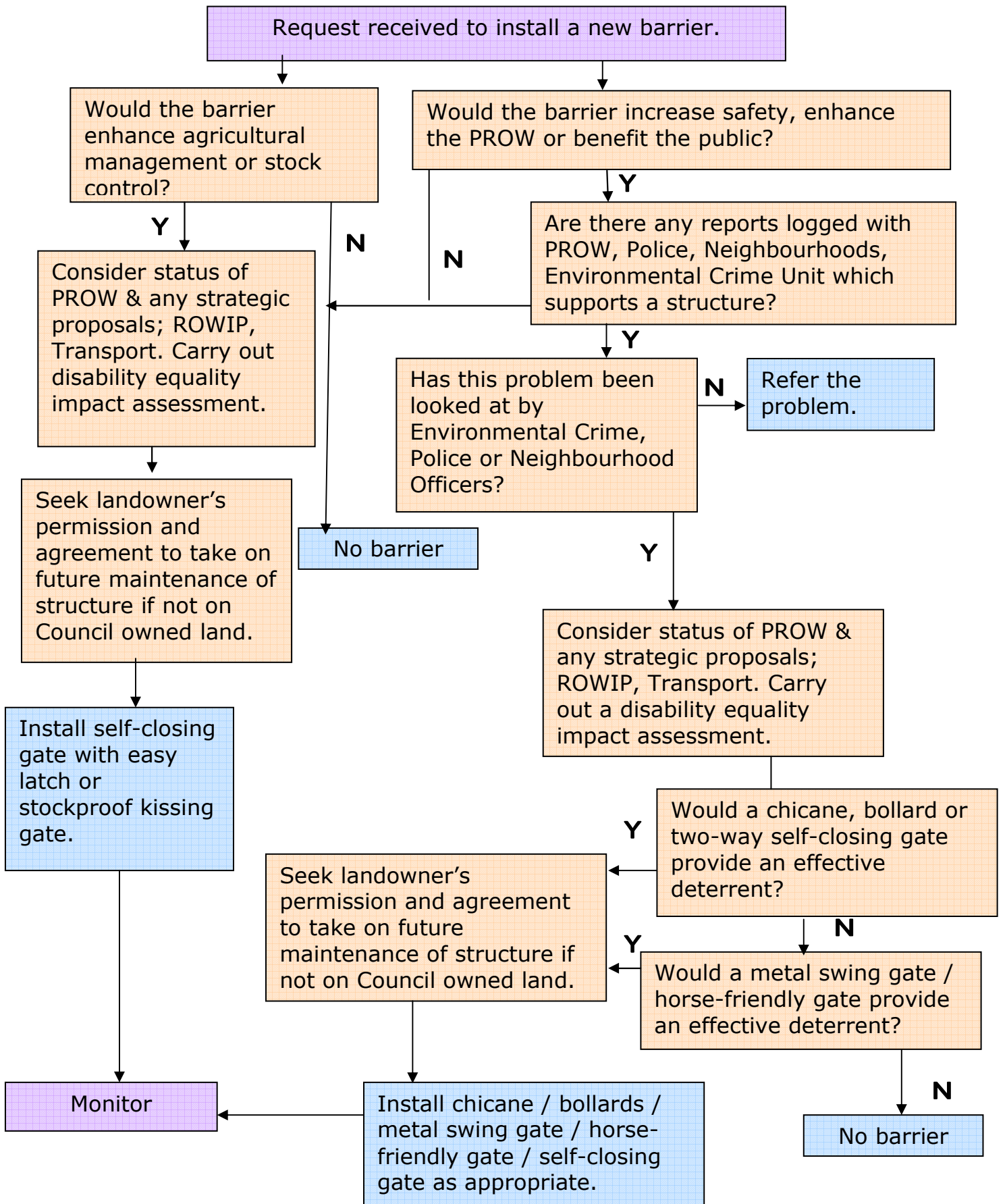

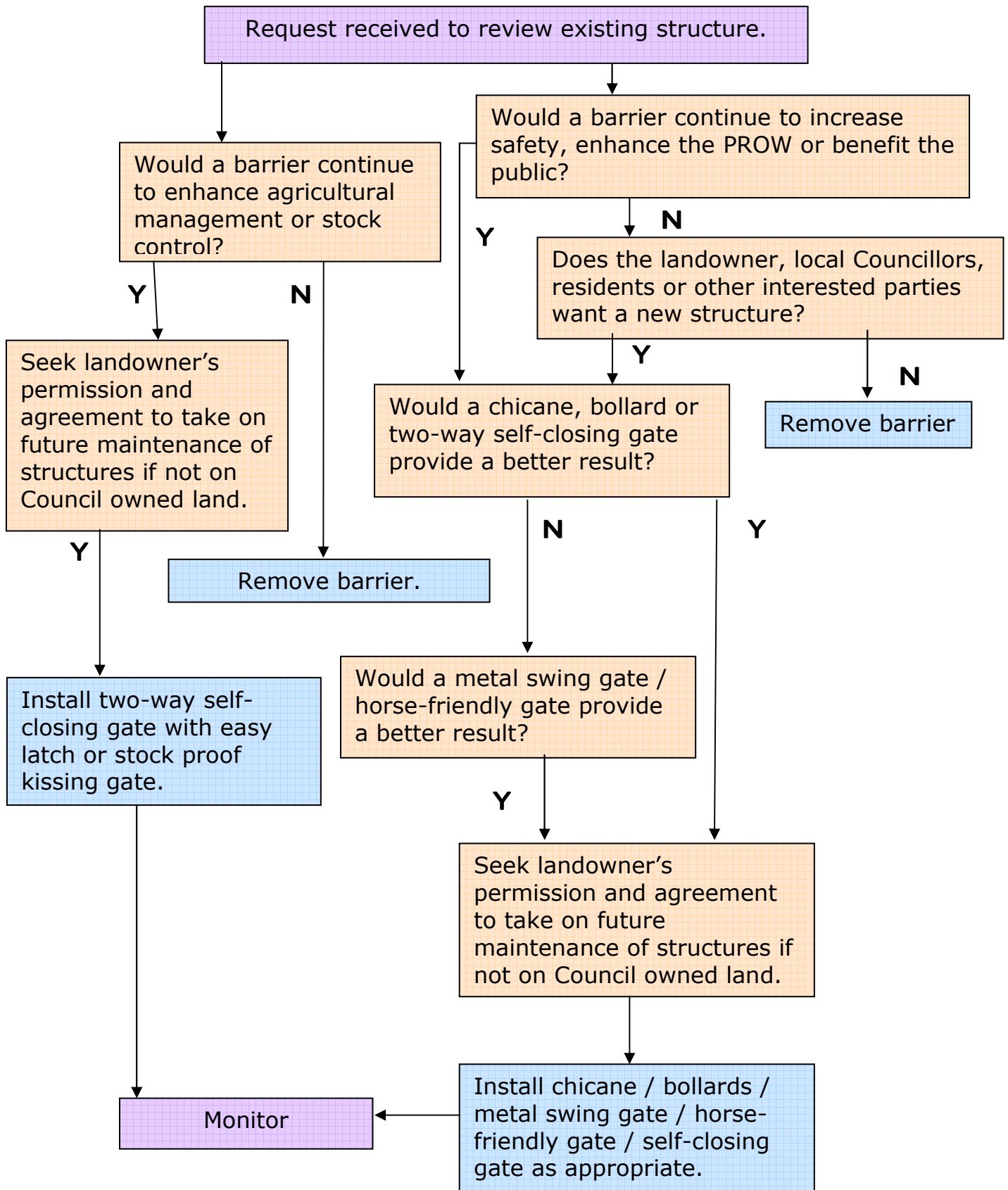

Would a barrier enhance agricultural management or stock control?	
Would a barrier increase safety, enhance the PROW or benefit the public?	
What is the status of the route (i.e. footpath / bridleway / permissive etc)	
Who is the landowner?	
Is this a new barrier or review of an existing structure?	
What would be the impact (+ / -) of the proposed barrier on access to the route for each user group?	
Blind/Partially Sighted:	
Cyclists:	
Deaf / Partially Deaf:	
Equestrians:	
Illegal Motor Vehicles:	
Learning Difficulties:	
Mobility Impaired	
Mobility Scooter Users	
Pedestrians with Pushchairs:	
Walkers:	
Wheelchair Users	
Other (e.g. anglers):	
Are there any reports logged with the Police, Environmental Crime Unit, Neighbourhoods or PROW Team of illegal activity or misuse of this route? Who has made these reports – local residents or users of the network?	
Has any illegal activity or misuse been investigated by Police, Neighbourhoods or PROW Team or Environmental Crime Unit, if so what was the outcome. If not pass on the details.	
Is the route identified in the ROWIP, Transport Strategy proposals, Greenheart as an important green corridor route, what will the impact be?	

If reviewing a structure has the landowner, local councillors, residents or other interested parties been consulted? If not why not?
Can access be gained to this route at other points? Is the route used as a through-route for motor vehicles or is illegal activity focussed on the area in general?
Would a chicane, bollard or two-way self-closing gate, stock proof gate provide a better result?
Would an approved metal swing gate / horse-friendly gate provide a better result?
Has an assessment been done on the impact to the overall route? If the proposed barrier could restrict some user groups, will it be installed strategically, restricting entire sections of path? If not what is the reason (e.g. access to a destination such as a beauty spot or other facility)?
Would any particular user group that has existing access, experience obvious increased difficulty using this route as a result of the proposed barrier?
Does the overall route conform to the specifications contained in this document?
Could a less restrictive option be employed successfully?
Recommendation and additional comments. Consider the full impact on all user groups with particular regard to disabled path users. Summarise the overall impact of this recommendation including both positive and negative effects. Should there be any negative impact on disabled access as a result of this recommendation how can this be justified? If further information is required to make a decision where/when can this be obtained? (Continue on a separate sheet if necessary).

Appendix Two Approved Specifications

The specifications on the following pages have been approved for use on Public Rights of Way and other routes on Council land in Wigan.

It should be noted that in some instances a combination of barriers will be required to accommodate the needs of both the landowner and the users. However it is inevitable that in order to provide access for a legitimate user, undesirable users; such as mini motos and small motorbikes will still be able to get through.

Chicane

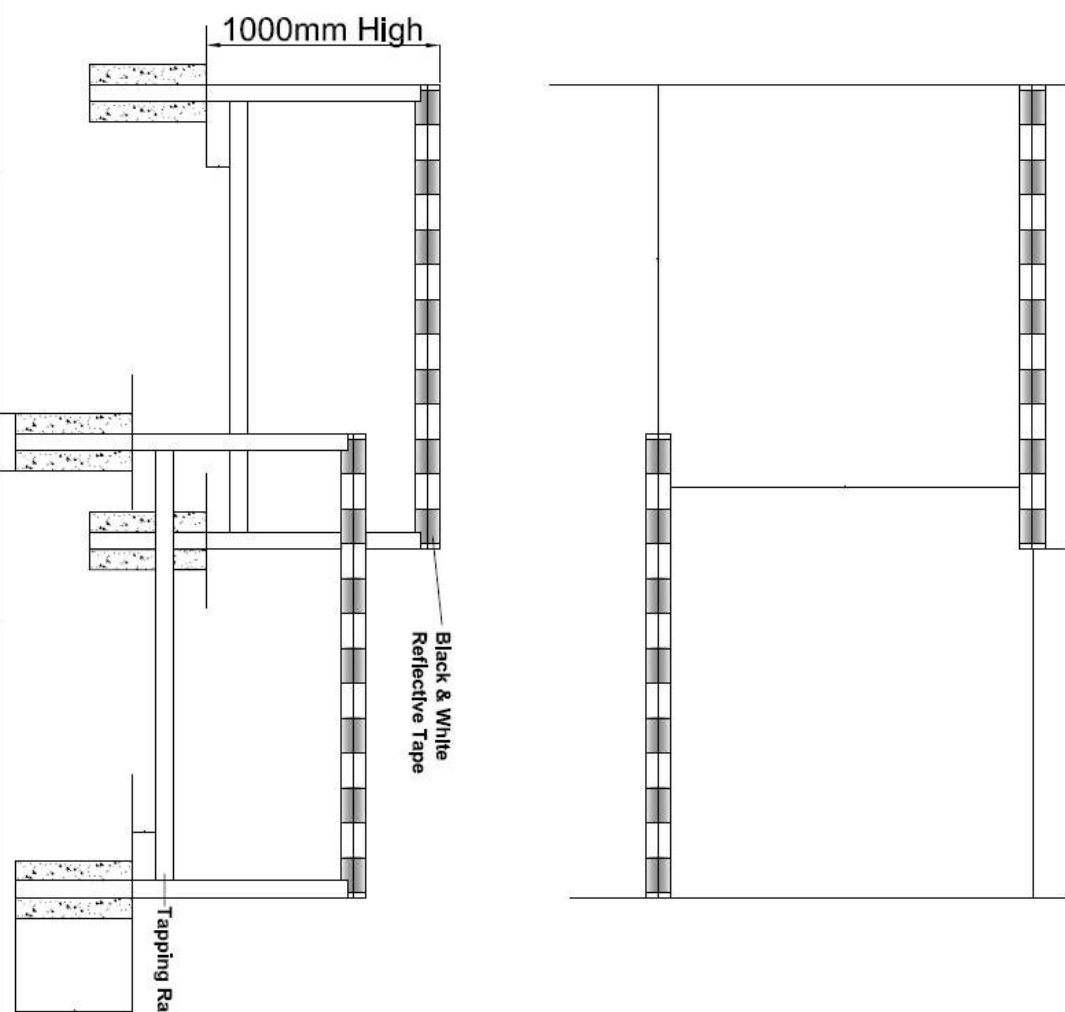
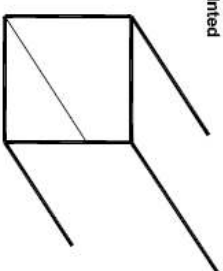
 <p>Wigan Council <small>Wigan, Greater Manchester, M16 9JG</small></p>	<p>PLACES DIRECTORATE - ENVIRONMENT</p>	<p>STANDARD DETAILS</p>	<p>Chicanes</p>
			
<p>75 mm Square Box Section galvanised then pointed</p> 			
<p>Notes:-</p> <ol style="list-style-type: none"> 1. Fabrication drawings are to be approved by the Project Manager prior to fabrication. 2. All steelworks to be blast cleaned to visual cleanliness Sa3 to BS EN ISO 8501-1, BS 7079-A1 (minimum) and surface profile guidelines as set out in Specification for Highway Works Clause 1904 3. All steelworks to be hot dip galvanised to BS EN ISO 1461:1999 and de-greased. 4. All posts to be 75mm square section and are to be inserted a minimum 500mm in ground, set on gravel/stone to prevent corrosion, with a concrete surround. 5. Unless otherwise stated in the Bill of Quantities the Contractor should ensure that the surfacing to the approach and at the location of the Chicane should be graded, level and compacted to the satisfaction of the Project Manager. 			
<p>Drawn: PFD Checked: ScaLANTS @ AD</p> <p>Date: JULY 09</p> <p>Drawing No: H6575/RW/6</p> <p>© Crown Copyright and database rights 2015 Ordnance Survey 100019676</p>			

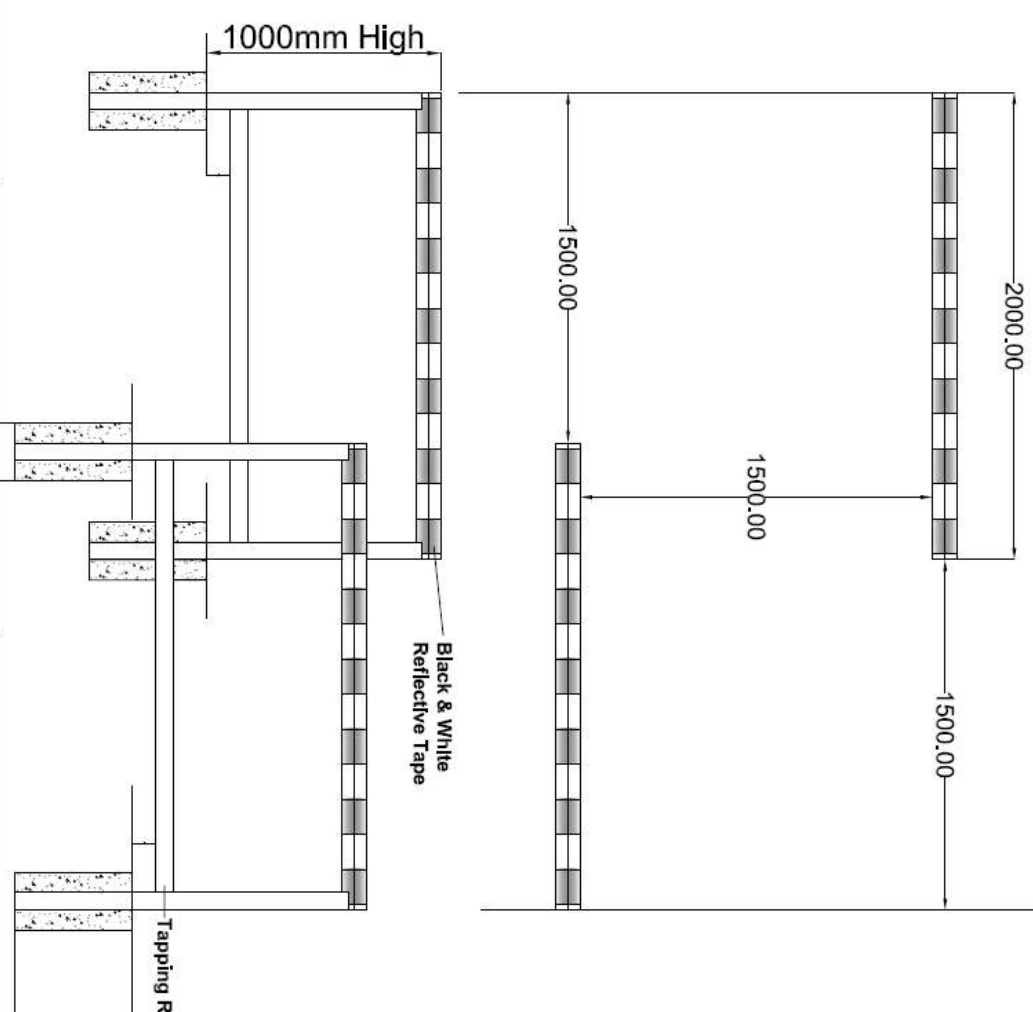
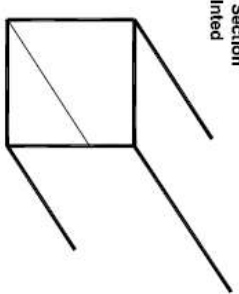
<p>PLACES DIRECTORATE - ENVIRONMENT</p>  <p>Wigan Council Planning & Environment Wigan, WA1 3QS WMT 305</p>	<p>STANDARD DETAILS</p>	<p>Chicanes</p>
		
<p>75 mm Square Box Section galvanised then pointed</p>  <p>Notes:-</p> <ol style="list-style-type: none"> 1. Fabrication drawings are to be approved by the Project Manager prior to fabrication. 2. All steelworks to be blast cleaned to visual cleanliness Sa3 to BS EN ISO 8501-1, BS 7079-A1 (minimum) and surface profile guidelines as set out in Specification for Highway Works Clause 1904 3. All steelworks to be hot dip galvanised to BS EN ISO 1461:1999 and de-greased. 4. All posts to be 75mm square section and are to be inserted a minimum 500mm in ground, set on gravel/stone to prevent corrosion, with a concrete surround. 5. Unless otherwise stated in the Bill of Quantities the Contractor should ensure that the surfacing to the approach and at the location of the Chicane should be graded, level and compacted to the satisfaction of the Project Manager. 		
<p>Drawn: JFD Date: JULY 09 Drawing No: H/6575/RW/6 © Crown Copyright and database right 2015 Ordnance Survey 10001679</p>	<p>Checked: ScahNTS @ AA</p>	



Two Way Self Closing Gate

<p>PLACES DIRECTORATE - ENVIRONMENT</p> <p>Wigan Council</p> <p>Wigan Council Planning Planning Directorate PO Box 100 Wigan, WN1 2AB</p>	<p>STANDARD DETAIL</p>	<p>Two Way Opening and Self Closing Bridleway / Footway Gate</p>	<p>Drawn: PFD Date: AUG 09 Drawing No: H/6575/RW/9 © Crown Copyright and database rights 2015 Ordnance Survey 100016078</p> <p>Checked: Scaled: NTS @ A4</p>
<p>Notes:-</p> <p>Two Way Bridle / Pedestrian with Self Closing Mechanism</p> <p>Gate Details are based on BS 5709:2006</p> <ol style="list-style-type: none"> 1. Latches to be visible, accessible and operated from both sides, with not more than 50N on spring balance force to fully open gate. 2. Hinges shall be fitted to the hanging posts with 9mm dia cuphead, square shanked bolts and nuts. 3. Bottom hinged should have a self closing mechanism. 4. All other bolts shall be M8 dia. with nuts and two no. washers. <p>General</p> <ol style="list-style-type: none"> 5. Timber used for posts should be oak, with all other timber to be approved softwood. 6. All timbers should be 'Tanalised' pressure treated. 7. All concrete is to be grade ST1 and shall be well rammed and compacted as filling proceeds 			<p>70 x 75 x 1000 Shutting Stile</p> <p>30 minimum</p> <p>175 x 175 x 1850 Hanging Post</p> <p>75 x 25 Braces</p> <p>100 x 75 Top Rail</p> <p>120 x 75 x 1000 Hanging Stile</p> <p>175 x 175 x 1850 Hanging Post</p> <p>75 x 25 Rails morticed into posts</p> <p>Self Closing Hinge</p> <p>1525 min. Bridleways</p> <p>1000 min. Footpaths</p> <p>550</p> <p>650</p> <p>All Dimensions in Millimetres</p>

Easy Access Metal Swing Gate

<p>PLACES DIRECTORATE - ENVIRONMENT</p> <p>Wigan Council Wigan Council Environment PO Box 300 Wigan WN1 2SA</p>	<p style="text-align: center;">ELEVATION</p> <p style="text-align: center;">Scale 1:20</p>	<p style="text-align: center;">PLAN</p> <p style="text-align: center;">Scale 1:20</p>	<p style="text-align: center;">Diagrammatic View</p> <p style="text-align: center;">Small Swing Gate Version 2</p>
<p style="text-align: center;">STANDARD DETAIL</p>		<p style="text-align: center;">Notes</p> <ol style="list-style-type: none"> 1. Fabrication drawings are site approved by the Project Manager prior to fabrication. 2. All assemblies to be fabricated to meet requirements ISO 9001:2015 and ISO 14001:2015 (Environmental) and shall conform to the requirements of the relevant standards for the applicable standards. 3. All assemblies to be fabricated to meet requirements ISO 9001:2015 and ISO 14001:2015 (Environmental) and shall conform to the requirements of the relevant standards for the applicable standards. 4. All gates to be fabricated to meet requirements ISO 9001:2015 and ISO 14001:2015 (Environmental) and shall conform to the requirements of the relevant standards for the applicable standards. 5. Gate: 1000mm high and 1000mm wide (approximate) with 100mm gate-close. 6. Gate: 1000mm high and 1000mm wide (approximate) with 100mm gate-close. 7. Unless otherwise stated in the Bill of Materials the Contractor shall ensure the location of the Small Swing Gate shall be as indicated in the drawings and shall be as indicated in the Bill of Materials. 	
<p style="text-align: center;">Small Swing Gate Version 2</p>		<p style="text-align: center;">Diagrammatic View</p>	
<p>Drawing: PFD</p> <p>Date: JULY 09</p> <p>Drawing No: H/657/SWRW/20</p> <p><small>© Crown Copyright and database rights 2015 Ordnance Survey 100019133</small></p>		<p>Checked:</p> <p>Scale: As Shown @ A2</p>	

Horse Friendly Gate (Wide)

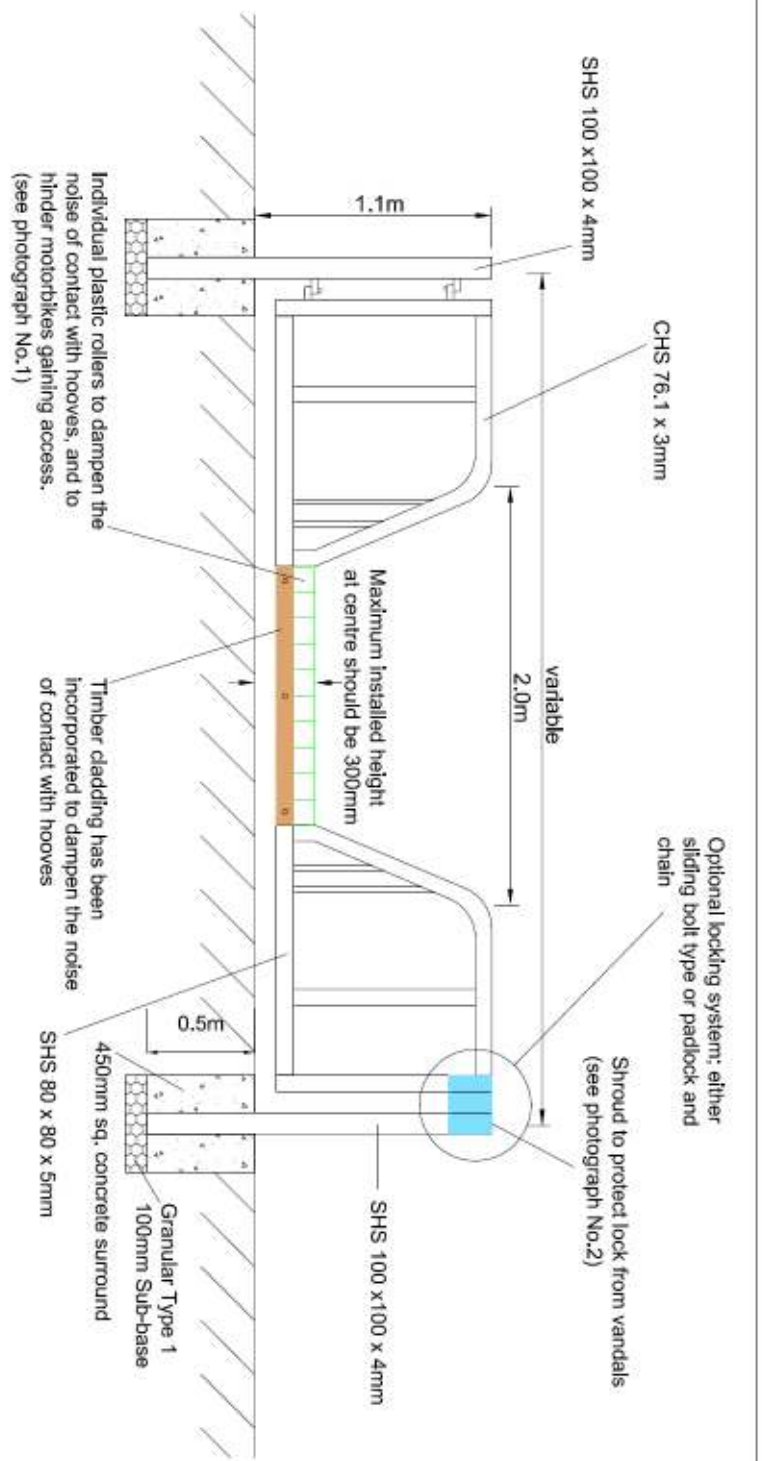
<p>PLACES DIRECTORATE - ENVIRONMENT</p>  <p>Wigan Council Highland Environment Wigan M16 2JH</p>	<p>STANDARD DETAIL</p>	<p>Horse Friendly Gate</p>	<p>Designer: PFD Date: JUNE 08 Drawing Number: H16575/RW/1a © Crown Copyright and permission 1/2008/2008 Checked: Scale: NTS @ A1</p>
 <p>Photograph No. 1</p>		 <p>Photograph No. 2</p>	
 <p>SHS 100 x 100 x 4mm</p> <p>CHS 76.1 x 3mm</p> <p>variable</p> <p>2.0m</p> <p>1.1m</p> <p>Maximum installed height at centre should be 300mm</p> <p>Individual plastic rollers to dampen the noise of contact with hooves, and to hinder motorbikes gaining access. (see photograph No.1)</p> <p>Timber cladding has been incorporated to dampen the noise of contact with hooves</p> <p>SHS 100 x 100 x 4mm</p> <p>SHS 80 x 80 x 5mm</p> <p>450mm sq. concrete surround</p> <p>Granular Type 1 100mm Sub-base</p> <p>0.5m</p> <p>Optional locking system: either sliding bolt type or padlock and chain</p> <p>Shroud to protect lock from vandals (see photograph No.2)</p>			

Horse Friendly Gate (Narrow)

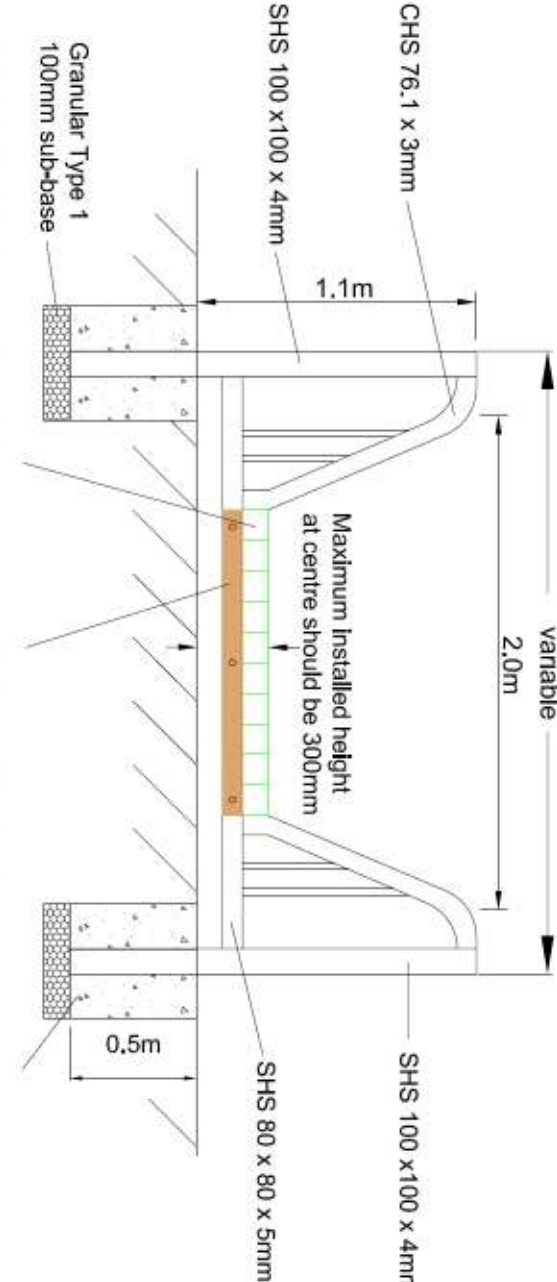
<p>PLACES DIRECTORATE - ENVIRONMENT</p>  <p>Wigan Council Planning Roads/Cheshire PO Box 100 Wigan WN1 2SE</p>	STANDARD DETAILS		Horse Friendly Barrier	
	 <p style="text-align: center;">Maximum installed height at centre should be 300mm</p> <p style="text-align: center;">variable 2.0m</p> <p>CHS 76.1 x 3mm</p> <p>SHS 100 x 100 x 4mm</p> <p>SHS 100 x 100 x 4mm</p> <p>SHS 80 x 80 x 5mm</p> <p>Granular Type 1 100mm sub-base</p> <p>1.1m</p> <p>0.5m</p> <p>Individual plastic rollers to dampen the noise of contact with hooves, and to hinder motorbikes gaining access.</p> <p>Timber cladding has been incorporated to dampen the noise of contact with hooves</p> <p>450mm sq. concrete surround</p>			
<p>Notes:-</p> <ol style="list-style-type: none"> Fabrication drawings are to be approved by the Supervisor prior to fabrication. All Steelworks to be blast cleaned to visual cleanliness Sa3 to BS EN ISO 8501-1, BS 7079-A1 (minimum) and surface profile guidelines as set out in The Specification for Highways Works clause 1904. All Steelwork to be hot dip galvanised to BS EN 1461 : 1999 and de-greased. 			<p>Drawn: PFD</p> <p>Check: JUNE 08</p> <p>Drawing Number: HM575/RW/1D</p> <p>© Crown Copyright and published under the Open Government Licence</p>	<p>Checked:</p> <p>Scale: NTS @ A3</p> <p>Drawn: NTS @ AS</p>

Horse Friendly Gate with Wheelchair Accessibility

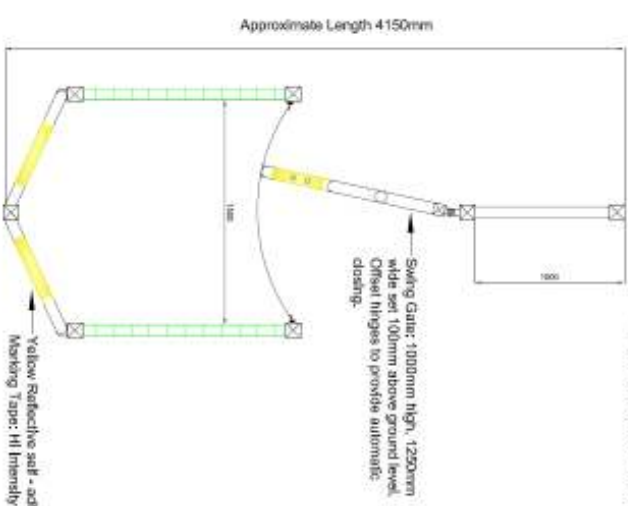
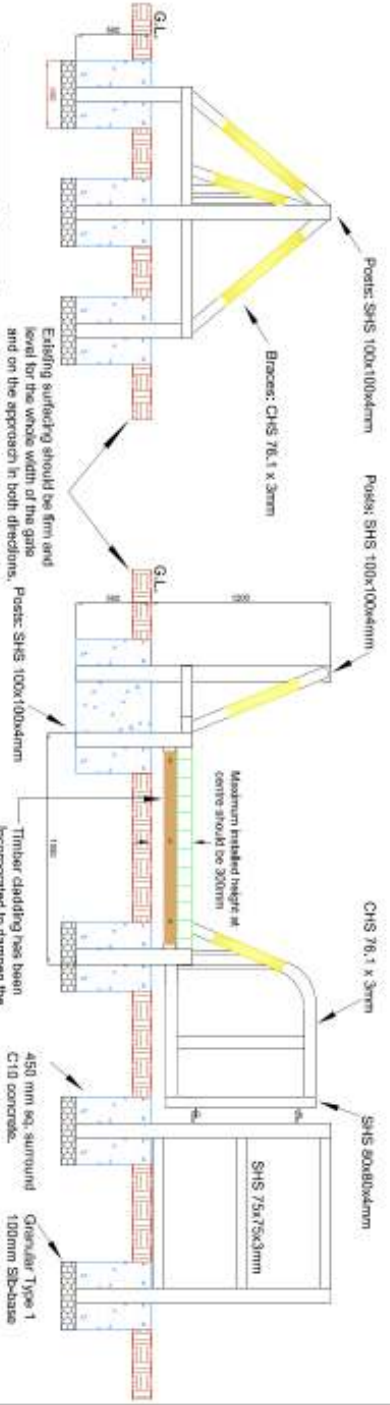
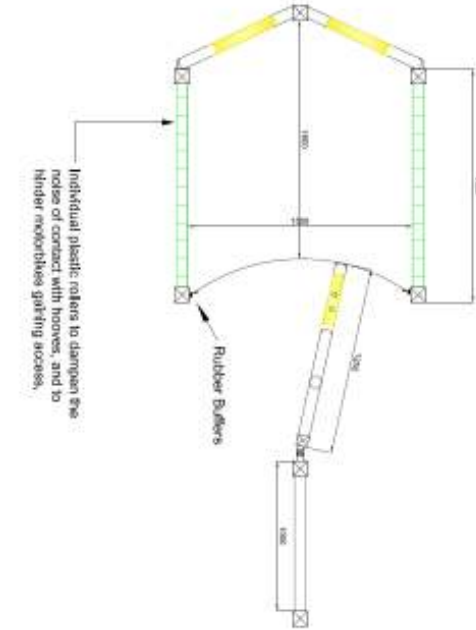
 <p>Wigan Council Wigan Council Planning Technical 01925 438300 www.wigan.gov.uk</p>	<p>PLACES DIRECTORATE - ENVIRONMENT</p>	<p>STANDARD DETAILS</p>	<p>Horse Gate with Wheel Chair Access</p>
<div style="display: flex; justify-content: space-between;"> <div style="width: 45%;">  <p>Approximate Length 4150mm</p> <p>Swing Gate: 1000mm high, 1250mm wide set 100mm above ground level. Offset hinges to provide automatic closing.</p> </div> <div style="width: 45%;">  <p>Posts: SHS 100x100x4mm</p> <p>Braces: CHS 76.1 x 3mm</p> <p>CHS 76.1 x 3mm</p> <p>SHS 50x80x4mm</p> <p>SHS 75x75x3mm</p> <p>450 mm sq. surround C19 concrete.</p> <p>Granular Type 1 100mm Slip-base</p> <p>Maximum installed height at centre should be 300mm</p> <p>Timber cladding has been incorporated to dampen the noise of conflict with hooves</p> </div> </div> <div style="margin-top: 20px;">  <p>Individual plastic rollers to dampen the noise of contact with hooves, and to hinder motorbikes/golfing access.</p> <p>Rubber Bulfers</p> </div> <div style="margin-top: 20px;"> <p>Notes:</p> <ol style="list-style-type: none"> 1. Fabricator drawings are to be approved by the Project Manager prior to fabrication 2. All steelwork to be steel checked to visual dimensions S33 to BS EN ISO 8530-1, BS 7079(A1) (interruption) and surface profile gauged as set out in Specification for Highway Works Clause 904. 3. All steelwork to be hot dip galvanized to BS EN ISO 1461: 1999 and de-greased. 4. All posts to be 100mm square section and are treated a minimum 500mm in ground with 150mm square concrete surround. 5. Gate: 1250mm x 1000mm high and set on 100mm above ground level. Offset hinges to provide automatic closing. 6. Guard rails to be 75mm square section. 7. Unless otherwise stated in the Bill of Materials the Contractor should ensure that the anchoring to the approach and at grades, level and compared to the satisfaction of the Project Manager. </div>			
<p>Client: PFD</p> <p>Date: JULY 09</p> <p>Drawing No: H1857AR/W/7</p> <p>© Crown Copyright and database rights 2011 Ordnance Survey 100000975</p>	<p>Checked:</p> <p>Scale: 1:20 @ A2</p>		

Stock Proof Kissing Gate

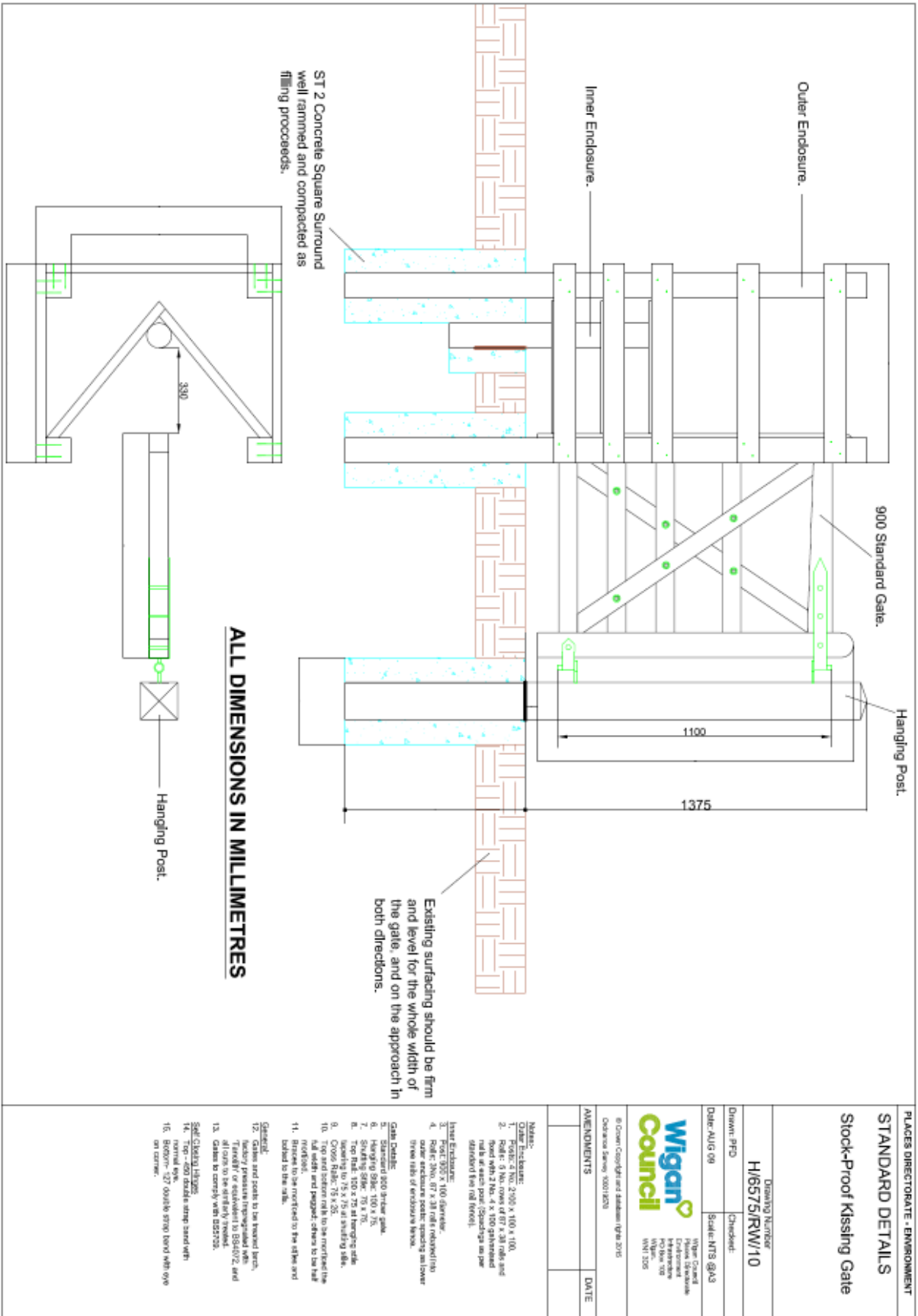

PLACES DIRECTORATE - ENVIRONMENT
STANDARD DETAILS

Stock-Proof Kissing Gate

Drawing Number
H/6575/RW/10

Drawn: PFD
Checked:

Dated: AUG 09
Scale: NTS @A4



© Crown Copyright and database (1998-2015)
Osborne Street, 10011/1020

AMENDMENTS	DATE

Notes:

- Outer Enclosure:**
1. Pile: 2 Nos. 2400 x 100 x 100.
 2. Pile: 5 Nos. rows of 67 x 38 rails and fixed with 2 Nos. 4 100 galvanneal strands per rail (200kg).

- Inner Enclosure:**
3. Pile: 205 x 100 diameter.
 4. Pile: 200, 87 x 38 rail embedded into three ribs of enclosure frame.

- Gate Details:**
5. Standard 900 stock gate.
 6. Sliding Sides: 70 x 70.
 7. Sliding Side: 70 x 70.
 8. Top Rail: 150 x 75 at hanging side, slanting to 75 x 75 at sliding side.
 9. Cross Rail: 75 x 50.

10. 100mm concrete rail to be mounted to slanting or parallel sides to the rail notches.
11. Ropes to be morticed to the side and lashed to the rail.

- General:**
12. Gates and posts to be treated with factory pressure impregnated with 'Timber' or equivalent to BS4102 and all join to be similarly treated.
 13. Gates to comply with BS5753.

- Self-Cleaning Hinges**
14. Top - 400 grade strap sand with normal eye.
 15. Bottom - 27 000/16 strap band with eye on bottom.

OPTIONAL HANDLE ON SWING GATE

DIAGRAMATIC VIEW

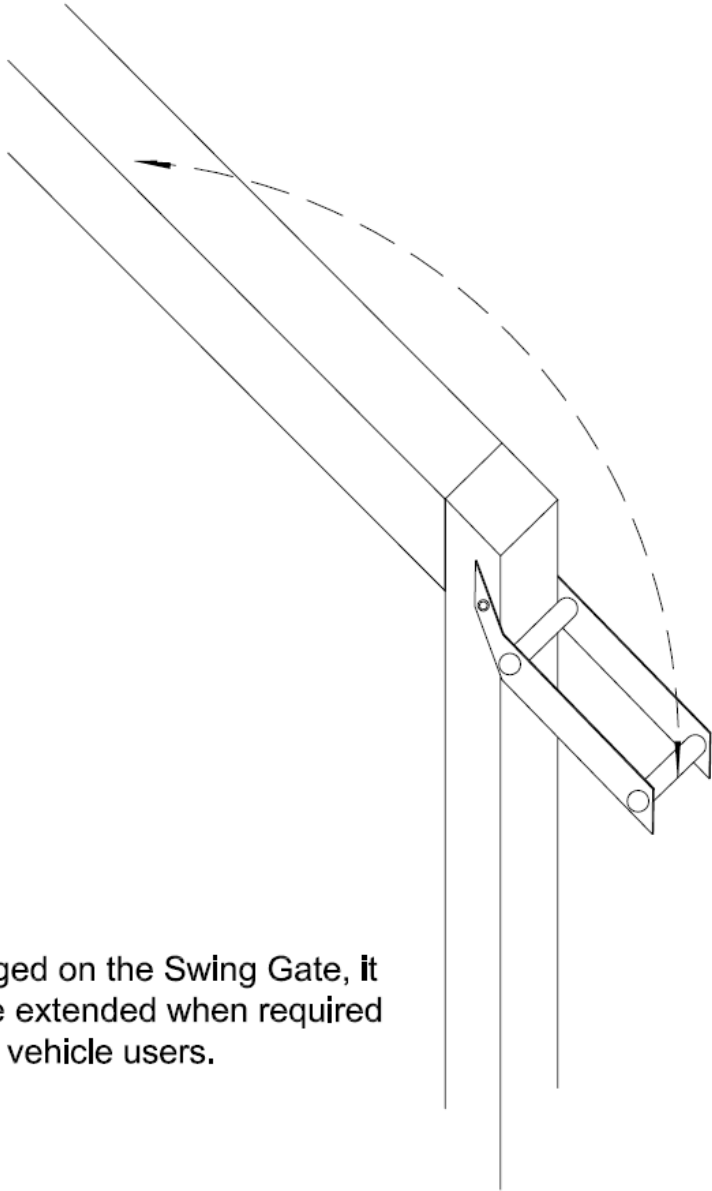

Handle hinged on the Swing Gate, it can also be extended when required for mobility vehicle users.

PLACES DIRECTORATE - ENVIRONMENT	STANDARD DETAILS	Optional Handle for Small Swing Gate	Drawn PFD	Checked
 Wigan Council Places Directorate Environment Infrastructure PO Box 100 Wigan, WN1 3DS			Date: JULY 09	Scale: NTS @ A4
			Drawing Number H/6575/RW/8	
			© Crown Copyright and database rights 2015 Ordnance Survey 100019578	

WOODEN HORSE STILE

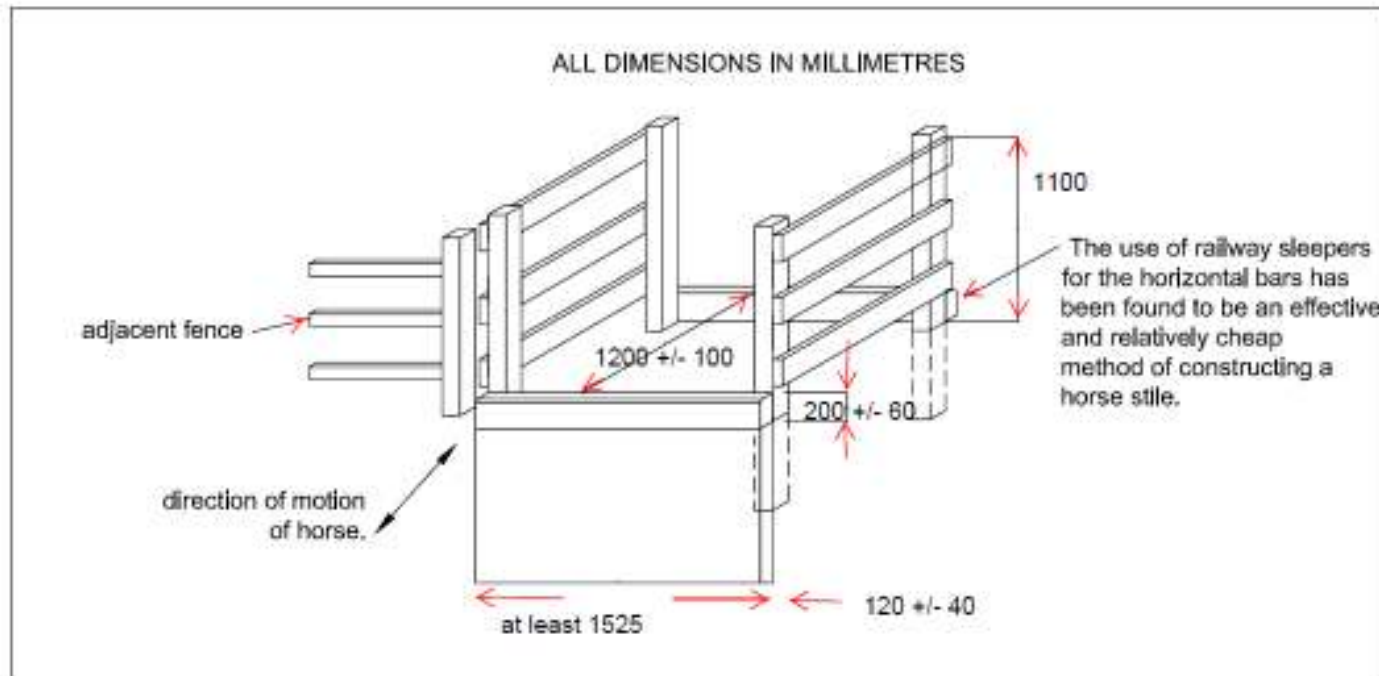

PLACES DIRECTORATE - ENVIRONMENT



Wigan Council
 Planning Department
 Environment
 Planning Unit
 Wigan
 WN1 1AA

STANDARD DETAIL

Timber Horse Stile

Drawn: PFD Checked:

Date: JUNE 06 Book: NTS @ A4

Drawing No: H6575/RW3

© Crown Copyright and database rights 2010
 Ordnance Survey 100019030

DOG GATE

