

LDF



July 2006

WIGAN LOCAL DEVELOPMENT FRAMEWORK



Design Guide for Residential Development



Supplementary Planning Document



Environmental Services Department

LDF

WIGAN LOCAL DEVELOPMENT FRAMEWORK

Design Guide for Residential Development Supplementary Planning Document

July 2006



Environmental Services Department



To assist people with particular needs this SPD can be made available on request in larger print, braille and in a number of alternative languages.

Arabic

"بالإمكان توفير هذه المعلومات في اللغة العربية."

Cantonese

這些資料可提供中文譯本。

Farsi

این اطلاعات به زبان فارسی هم میتواند در دسترس شما قرار گیرد.

French

Disponible en francais sur
demande

Gujurati

આ માહિતી ગુજરાતીમાં મળી શકે છે.

Urdu

یہ معلومات اُردو میں بھی دستیاب ہو سکتی ہیں۔

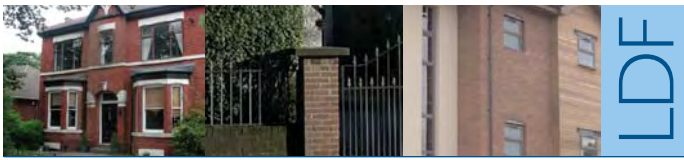

Contents

PART	ONE	Introduction	1
		Purpose of the guide and how to use it	1
		What do we mean by the term 'house'?	2
		Status of the guide	2
PART	TWO	Planning application process	3
		Community involvement	3
		Pre-application discussions	3
		Planning application requirements	4
		Design and Access Statement	4
		Building Control requirements	4
		Managing the development process	4
		PART	THREE
Principle 1 Making more efficient use of land	5		
Principle 2 Achieving better accessibility to local facilities and public transport	6		
Principle 3 Supporting crime prevention and community safety	6		
Principle 4 Creating more socially inclusive communities	6		
Housing, tenure, type and size	6		
Affordable housing	7		
Special housing needs	7		
Principle 5 Achieving energy efficiency and innovation in building design	7		
Principle 6 Protecting amenities	8		
Principle 7 Access for all	9		





PART	FOUR	Design considerations for sustainable development	9
		Character and identity	9
		Retention of existing buildings and site features	10
		Density	11
		Layout	11
		Enclosure of spaces	11
		Scale, height and massing	12
		Establishing visual interest	13
		Visual impact	13
		Convenient movement routes	13
		Parking provision and servicing	13
		Materials and building detailing	14
		Capturing views, creating focal points and vistas	14
		Landscaping	15
		Public open spaces	15
		Other outdoor amenity spaces	15
		Private individual gardens	15
		Private communal gardens	15
		Bicycle stores	16
		Bin stores	16
		Biodiversity	16
		Boundary treatments	17
		Provision of public art	18
		Energy and water conservation	18
		Crime prevention and community safety	18
		Access and movement	18
		Structure	19

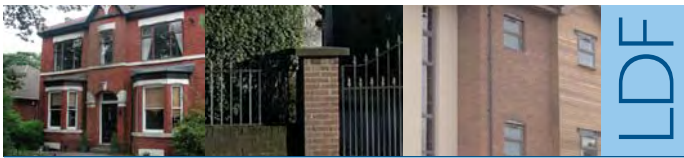

		Surveillance	19
		Ownership	19
		Physical protection	19
		Activity	19
PART	FIVE	Case Studies	20
		Case study 1: Apartment development	20
		Character and identity of the area	20
		Height of development	21
		Visual impact	21
		Provision of amenity space	21
		Private outdoor garden/seating area	21
		Maintaining privacy to ground floor residents	21
		Bicycle parking provision	22
		Case study 2: Infill development	22
		Case study 3: One to one house replacement and plot sub-division	24

Appendices

APPENDIX A	Access to information and contact details	25
APPENDIX B	Planning policy context	28
APPENDIX C	Planning application requirements	31
APPENDIX D	Design and Access Statement	32
APPENDIX E	Building Control requirements	35

Adoption Statement and Sustainability Appraisal

Wigan Council adopted the Supplementary Planning Document (SPD) Design Guide for Residential Development on 12th July 2006.

A Sustainability Appraisal (SA) of the SPD was conducted to discover how it might influence the sustainability assessment made in 2003 of the relevant Unitary Development Plan policies and proposals. The conclusion was that the SPD was found to have no negative sustainability impact. A copy of the SA is available on request, and the impact of the SPD will be monitored in the future.





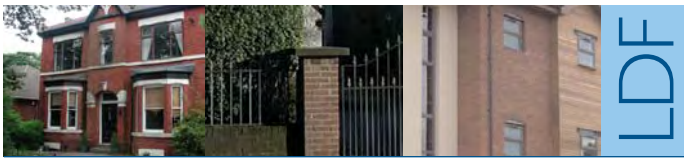

ONE

Introduction

Having a decent home in a pleasant neighbourhood has long been an aspiration of most people. We expect our homes to be attractive and reflect our tastes and status. We expect our neighbourhoods to be attractive, safe and convenient, and we hope our homes will provide a good investment. We also as a society want our housing to be environmentally sound.

These aspirations are reflected in government and local planning policies and in Wigan's Community Plan. Both of these documents agree that good design is the key to achieving our aspirations and raising the standard of housing.

Government and local policies refer to 'building sustainable communities' and achieving 'sustainable development'. These mean that:

- well designed housing can achieve good neighbourhood environments;
- we need to design for everybody, for tomorrow's needs as well as today's and to preserve scarce resources;
- we need to offer a wide choice of housing to suit all lifestyles.

As a Council, we place a high value on achieving the highest possible standards of design. We consider that good quality design need not necessarily cost more money particularly where design is considered from the outset, before land is secured and values are fixed.

National, regional and local policies emphasise the need for higher density development on previously developed, or 'brownfield' land. The Government and Commission for Architecture and The Built Environment (CABE) have concluded that **'standard design and standard layouts will not work on high-density developments. Increases in density must accompany increased attention to design quality: there are clear commercial rewards when this course is followed.'**

Purpose of the guide and how to use it

This guide has been written, not to show you how to design, but how to think about design.

The purpose of the document is to guide the work of developers, designers, Councillors, Planning Officers, and the public to help achieve high standards of housing development. The main aims of the guide are to,

- Raise general awareness of the value of good design and how it can be achieved;
- Expand on Planning policies set out in government guidance and regional and local development plans (see Appendix B – Planning policy context on page 28 for further details);



- Provide a clear set of guidance and standards to explain what the Council will expect from new housing developments;
- Improve the quality of submissions for planning approval, in order to achieve better quality development and quicker decisions.

The design guide is not intended to replace the skills or the need for qualified Architects, Landscape Architects, Town Planners and designers.

The most important factor in achieving good design is to employ a good, qualified designer!

What do we mean by the term 'house'?

For the purpose of this guide, when we refer to the term 'house' it does not relate to a specific type of development but rather incorporates a variety of living accommodations, for example terraced, detached and semi-detached houses. It also includes apartment developments, which are an example of high-density living where the individual occupies only a proportion rather than the whole of the building.

Status of the guide

The guide holds the status of a Supplementary Planning Document (SPD). This means that it both supports and reinforces the planning policies as set out in the adopted Replacement Unitary Development Plan (2006) and the transitional arrangements for the Wigan Council Local Development Framework. The SPD is a material consideration and will be used to help decide planning applications and defend decisions made at appeals.

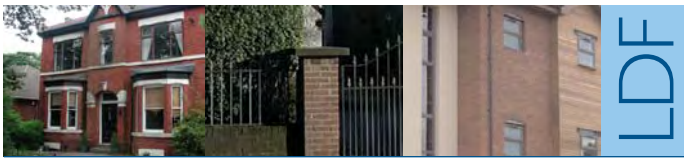

TWO

Planning Application Process

Community involvement

Local communities have a justifiable interest in new developments and can provide a wealth of local knowledge and insight that can help inform the design process. Local communities will not only include residents but those who work in the area, including local interest groups, disability groups and the voluntary/community sectors.

As a Council, we are committed to involving the community in the planning application process in the following ways:

- **Inform** – publicising and notifying people of proposed developments.
- **Consult** – requesting views on proposed developments and considering these before making a decision.
- **Involve** – ensuring that community involvement exercises are undertaken for major development proposals.

The extent of community involvement we encourage and/or undertake in the decision making process will depend upon the type of application that is being considered and will be different at different stages in the application process. We have a number of guidance leaflets

that set out our requirements for community involvement. These leaflets are,

- **Community involvement in the planning application process**
- **Publicity for planning application – Our code of practice**
- **Consideration of planning applications at Planning Committee**

All leaflets are available from our web site or can be requested from our Development Control administration team please see page 25 for all contact details.

Pre-application discussions

We welcome pre-application discussions with applicants. Ideally, these should be carried out at an early stage, so that the scope of relevant policies and any likely difficulties can be identified. It will be possible to involve specialists in matters such as highways, access, urban design, conservation, protected trees and ecology if necessary.

Depending on each individual case the Council can also advise on other external agencies, organisations and interested parties who may require specific discussions.



Planning application requirements

To ensure that high quality development occurs and to avoid unnecessary delay, planning applications must show sufficient information. Plans and drawings should be clearly and professionally presented and should illustrate how the proposal relates to its immediate context. Please refer to Appendix C: Planning application requirements on page 31 for further details. In addition, the Council has produced a Planning Checklist and Applying for Planning Permission Guidance notes, which are available from our website and can be requested from our Development Control administration team.

Design and Access Statement

We expect all applicants who are seeking planning permission to demonstrate how they have taken account of the need for high quality design in their development proposals and that every opportunity has been taken to achieve an accessible environment for all.

For any planning applications for new houses a Design and Access Statement will be required to support the application.

However, a Design and Access Statement will not be required for householder applications for developments such as extensions, conservatories, sheds, garages and fences.

For further details please refer to Appendix D on page 32.

Building Control requirements

The Council's Building Control section deals with the building regulations and other related legislation, and they have a responsibility to check and

supervise any plans and building works in the interest of the public's health and safety.

All new development must satisfy the requirements of the building regulations and the main criteria for these requirements have been provided on page 34.

If you have any questions concerning the requirements or would like to discuss your application, please contact our Building Control section.

Managing the development process

Achieving planning permission for a high quality proposal is only one of the early stages in the overall development process. Sometimes having achieved planning permission, the quality of schemes is subsequently reduced, for instance due to decisions taken on economic grounds or in response to unanticipated difficulties on site.

Whilst revisions to designs are often necessary and reasonable in response to changing circumstances, we will be vigilant to ensure that without good reason:

- Good designers employed to obtain planning permission are not replaced by less skilled designers for the detailed or implementation stages;
- The quality of materials or landscaping are not reduced from those proposed in the original application;
- Building or landscape features that are proposed to be conserved, such as mature trees, are protected during construction.

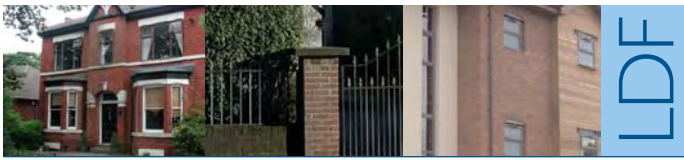

THREE

General planning and design principles

There is no magic formula you can apply to design that can tell you what is the most suitable approach to development. However this guide will show there are a number of different planning and design principles and design considerations, which should be used to help inform the final development solution.

This section of the document sets out the planning and design principles, which are requirements of residential developments irrespective of its scale. The following section, Part Four provides a number of design considerations that set out detailed guidance and advice. Please note however that some planning and design principles and design considerations are inter-related and linked, and therefore it may not always be possible to make a clear distinction between them. We therefore recommend that the guide be read as a whole document.

However please be aware that the proportion of design effort spent on each principle and objective will vary greatly depending upon the size of the site and the scale of the development.

Principle 1:

Making more efficient use of land

In order to meet our long-term housing needs, we need to ensure that we are making the most efficient use of land available to us by increasing residential densities. However, the benefits of higher density development must not be delivered at the expense of the quality of the existing environment.

Draft PPS 3 calls for residential development to make the best and most efficient use of previously developed land, with consideration given to the opportunities that the site location offers. Any development proposal must maintain a positive relationship with its surroundings and must be appropriate to the context and character of the area.

Policy **RID – The Design of New Residential Development and House Extensions** states that any development proposal for 3 units or more should have a density of between 30 and 50 units per hectare, and in general, planning permission will not be granted if any development proposals are less than 30 units per hectare. A greater intensity of development will be sought at places with good public transport accessibility and where the character of the area justifies it.



Principle 2:

Achieving better accessibility to local facilities and public transport

The success of any new residential development scheme depends on how well it is connected to existing areas, established routes and local facilities. All forms of movement routes, for example roads, streets, footpaths, cycleways and public transport paths must be designed to help link people with places, whilst responding to the needs of residents by offering a greater choice of different types of routes.

Any new residential scheme should be based upon the concept of creating a **'walkable neighbourhood'**, where local services are readily accessible, with all movement routes designed to be practical, attractive and accessible for all. (Please see page 13 for further details on 'walkable neighbourhoods').

Movement routes are also a crucial component in helping to contribute to the character of the urban area and can greatly influence how we can travel. None of the routes should be designed to function in isolation, rather the aim should be improve and establish new routes through the area, not simply to and from the site.

Linking the site to its content



Principle 3:

Supporting crime prevention and community safety

Designing out crime and tackling the issues of the fear of crime are essential aspects that should be considered during the design and planning process. All planning applications should demonstrate how crime prevention measures have been considered by including this in the Design and Access Statement.

Early consultation with the Greater Manchester Police Architectural Liaison Unit is recommended to discuss all aspects of crime prevention measures. Please refer to Appendix A for further contact details.

Principle 4:

Creating more socially inclusive communities

New development should respond to people's needs and provide a framework within which mixed and balanced communities have the flexibility to become established and grow. This could be achieved in a number of the following ways,

Housing tenure, type and size

Depending on the scale of new developments they will be expected to secure a wide social mix and balance of different types of households, which incorporate diverse ages and economic status and different levels of mobility and independence.

A diverse mix of housing types, sizes, uses and affordability will contribute to the creation of more attractive neighbourhoods

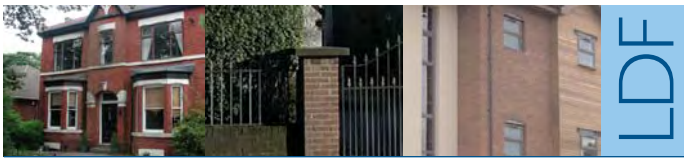

The design of buildings should be accessible and provide a level of flexibility that allows for easy conversion between live and work uses, or that accommodates for changes in mobility.

The developments should be designed to be robust and adaptable over time. This can be achieved by providing sufficient internal and external spaces that provide potential opportunities for the house to be extended, converted and adapted.

Affordable housing

The Council has prepared a SPD on 'Affordable Housing Provision in New Residential Developments' to help those applicants of medium to large scale developments determine what level of provision is required.

When referring to the different scales of development the terms small, medium and large will be referred to and they are defined as,

Size of development:	Number of units:
Small-scale	less than 10 units
Medium-scale	between 10 and 50 units
Large-scale	50 or more units

We expect the provision of affordable housing to be designed and implemented to an equally high standard and quality as the other housing on the site.

A copy of the SPD can be viewed and downloaded from the council's web site at www.wigan.gov.uk or can be purchased for a small fee from the Environmental Services Department office.

Please refer to Appendix A for contact details.

Special housing needs

The successful integration of special and general needs housing should be planned from the outset, with solutions tailored to individual site circumstances rather than using standardised buildings.

Principle 5:

Achieving energy efficiency and innovation in building design

Delivering sustainable homes and places is one of the most important challenges we face. This is because nearly every decision we make about developments place constant demands upon the environment and the earth's resources. For example,

- The availability of land and production of building materials from raw materials for example aggregate used in concrete, are in short supply.
- The construction industry uses 70% of the earth's timber, however the majority of this wood does not come from sustainable managed forests.

One of the key principles to help achieve sustainable homes and environments is based upon improving energy efficiency and so reducing the greenhouse gases that cause climate change. Carbon Dioxide (CO₂) is one of the main greenhouse gases, yet the housing industry produces over a quarter of CO₂ emissions via the inefficient use of energy during the construction process and the heating of the home after completion.



We need to improve energy efficiency in order to keep the consumption of renewable natural resources within the limits of their replenishment and minimise energy use and waste during construction and after completion.

To ensure that the customer is being offered a wide choice, show houses and flats which are being constructed as part of medium to large scale developments must be fitted out with energy efficient and water saving household appliances. In order to secure this commitment an appropriate planning legal agreement will be used.

Principle 6: Protecting amenities

It is important that the planning and design of residential developments retains the privacy and amenity of adjoining properties as well as those of new residents. In order to ensure that adequate levels of privacy and amenity for occupiers of new and existing neighbouring properties are maintained the following interface (separation) distances between properties should be applied;

- A distance of no less than 21.5 metres between the main elevations containing windows of habitable rooms. However

this distance may potentially be reduced where the design or orientation is such that the privacy of the neighbouring property is not compromised.

- No less than 12.2 metres between the main elevations and those that do not contain primary windows of habitable rooms. However this distance could be reduced if the proposal is designed or orientated in such a way avoid the development appearing over-dominant from the neighbouring properties.

These standards are in accordance with policy **RID – The Design of New Residential Development and House Extensions**. The minimum interface distances given may need to be increased where steeply sloping sites produce particular problems of overlooking or where developments exceed two storeys. **As a general rule for every additional storey or on steeply sloping sites, an increase of 3 metres must be added to the minimum interface distances set out above.**

Interface distances



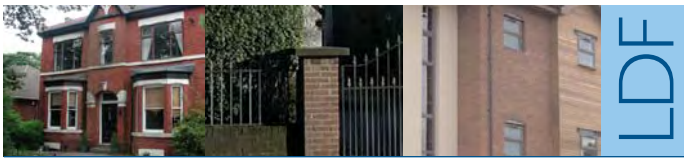

Principle 7:

Access for all

Every opportunity must be taken to ensure that an accessible environment is created. It should be easily used, safe, predictable and well designed and usable by all regardless of age, gender or disability and recognise the different ways that people use it.

- Pedestrian and vehicle routes should be clearly distinguished using texture and colour. Path edges should be defined, and surfaces should be firm and durable, avoiding materials such as cobbles, loose gravel and shingle. Pathways should be of sufficient width to provide enough space for all users and dropped kerbs and tactile paving should be provided at all points where people need to cross a vehicular route to continue their journey.
- In order to create an accessible environment gradients should be as gentle as possible. If a gradient is between 1 in 12 and 1 in 20 it must be designed as a ramped approach rather than steps.

For further access advice and guidance please contact our Building Control section and Access officer, the contact details can be found on page 25

FOUR

Design considerations for sustainable development

Character and identity

In assessing the impact of any new development on an existing residential area the Council wishes to ensure that the local character and identity of an area is maintained or enhanced. It is important to recognise that 'character' and 'identity' are qualities that are determined by a number of considerations that can be derived from key common features, for example

- Local building types
- Local materials
- Topography of the land
- Landscaping setting and features
- Uniform boundary treatments
- Strong building lines
- Plot widths
- Landscape setting and features
- Footprint and depths of building/s
- Architectural styles
- Patterns of existing access points
- Roof forms
- Window style and proportions
- Typical building details
- Existing rhythm of the streetscene
- Spaciousness – patterns of visual separation between buildings

It is important to recognise that in order to construct some of these features appropriate traditional building skills are needed.



These considerations are based upon policy **EV3A – Design of Development**, in particular **clause A – Character and Identity**. Please see Appendix B for more information.

When assessing the character and identity of an area, the findings of the site survey should be used to inform the character and identity of the development as well as the final house design and site layout solutions. The level of detail needed for a site survey will greatly depend upon the scale of the development. However there are many examples within the borough where residential areas are located within conservation areas or contain listed buildings and building of local interest. In these circumstances the assessment of the character and identity should reflect these particular features.

Building details



gable detail



front door detail



eaves detail



chimney and side elevation



window detail



mortar verge detail

Retention of existing buildings and site features

Policy **EV3A, clause A** states that where appropriate, existing buildings and elevations should be retained, sympathetically converted and incorporated into the scheme. This is particularly important if the building/s is of local architectural and historic value, listed or located within a conservation area.

Often on sites where buildings of local architectural and historic values are located they are supported by site features for example, gardens, substantial planting, trees, fences, walls, hedgerows and high quality ground surfaces materials. Where demolition and/or full site clearance is proposed, any replacement development should take into account the contribution the existing buildings/elevations and site features already make to the local environment, as any future schemes will only be permitted where there is no loss to the visual character, quality and interest of the local area.

Buildings of local interest



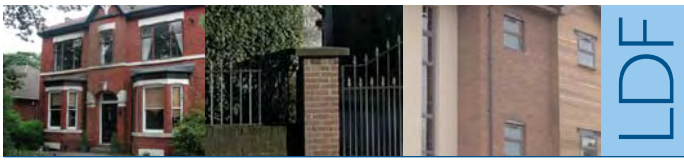

Density

New housing developments must be efficiently designed in order to deliver the necessary density requirements, and also maintain a relationship to the physical surroundings of the site. **It is important to recognise that the density requirement is only a measure. It is product of design, not a determinant of it.**

Higher densities of development will generally not be considered appropriate within existing settlements that are poorly served by public transport and are not readily accessible to local facilities.

Delivering high-density living does not mean a reduction of space in and around the home. Any development should provide sufficient storage space both inside and outside, for example for recycling and domestic waste bin storage.

The site layout must create sufficient amenity space around the development in order to retain a feeling of spaciousness. The size of amenity spaces will be dependent upon the character of the area.

Layout

Well planned and designed residential environments are based upon a clearly defined and simply laid out framework of development. The framework sets out the physical structure of the residential environment by arranging, positioning and linking the buildings, open spaces, movement routes and landscaping in order to shape the quality, attractiveness and character of the whole area. This framework also responds to different levels of detail and scale.

Requirements and guidance will be set out for these different levels of detail and scales of development throughout the guide. For the purpose of this document the definition for the different level of details refers to, the individual building, the site itself, the area immediately surrounding the site and the wider neighbourhood.

Enclosure of spaces

Because the position of building/s on site can greatly influence the function and quality of the spaces they enclose, the site layout must clearly show how it successfully links the design of the inside spaces of the house with the outdoor spaces on the site.

Any site layout must aim to reflect the established building lines, incorporating the continuity of street frontages and enclosures of space.



Scale, height and massing

Determining the appropriate scale, heights and massing of new developments will depend greatly upon a number of points, which are

- the location of the site,
- the physical characteristics and conditions of the site itself,
- the scale and proportion of the surroundings, and
- the positive response to any adjoining buildings, the spaces around them, the topography, the general patterns of heights in the area and views, vistas and landmarks.

The scale and massing of any development will be greatly influenced by the depth and shape of the floor plans. An imaginatively designed floor plan

(when worked up three dimensionally) will allow the built form to be divided into recognisable sections by projecting or setting back key sections of the development.

To ensure that the height of the development remains consistent with its context the design solution should consider using the roof space as additional living space.

The massing and height should not overshadow and overlook any adjacent buildings and spaces.

Buildings should be arranged to assist in the variation of building heights, in order to break up the overall mass of the development and increase the visual interest.

Variations in building heights and types



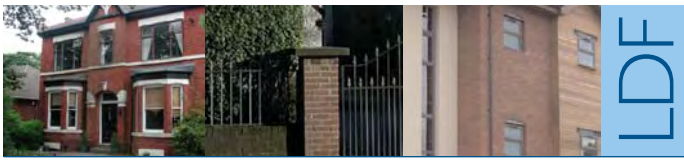

Establishing visual interest

New developments must be well articulated, for example with a variety of bays and gables, in order to avoid featureless elevations. These must be in scale and proportion with the whole of the building, whilst providing a variation in roof heights. Variations in materials or areas of glazing can also add interest.

Visual impact

Higher density developments could have an adverse effect upon the existing character, which is often dominated by a landscape setting. It is important that buildings continue to be sufficiently widely spaced to allow the established landscape and pattern of development to dominate.

Creating and maintaining visual separation between existing and new buildings helps to create a perception of spaciousness.

Convenient movement routes

New routes should be established through the area, connecting the new development to other neighbourhoods, town centres, established strategic bus routes and railway stations.

Pedestrian access to local bus/rail services should be achieved by the shortest distance and by the most direct and secure route.

For the purpose of this SPD, a general guide of up to 400m is taken as a reasonable walking distance to a bus stop and up to 800m to a railway station. However these distances may vary with the topography and the quality of the service being accessed.

A good bus service is defined as one with a 20-minute frequency in peak traffic hours.

Parking provision and servicing

Imaginative design solutions must be provided for car parking, in order to visually enhance the appearance of the street and the surrounding area.

Car parking should not be located directly in front of the house/s as the established building line would be significantly altered as a result. If possible, car parking should be located to the rear of the house/s within a private enclosure. However, if car parking can only be provided to the front of the house/s a balance between the car parking and garden provision should be achieved.

Higher density developments should investigate the possibility of underground or undercroft parking provision.

Where communal car parking is being proposed it should be designed as small grouped areas that are suitably landscaped in order to help soften the visual impact. It is important that all communal parking is sited as close as possible to the houses they serve.

The design of the development should also allow for access and facilities for emergency and service vehicles.

In accordance with the RUDP, policy A1S – Parking in New Development and as set out in Appendix 9 – Parking Standards on page 179, the following car park standards should be applied. Please be aware the parking standards set out within the RUDP is the maximum requirements.



Houses

- For any house developments with up to 3 bedrooms, 1 car parking space must be provided.
- For any house development with 4 or more bedrooms the requirement will be for 2 spaces.
- The surface and width of driveways for all types of houses should take into account the needs of all users, particularly people with disabilities, older people and families with young children.
- When determining the level of provision please be aware that the provision of garage/s is not included in the calculations.

Apartment developments

- For any residential developments with 2 bedrooms or more located outside town centres the standard is for 1.5 spaces per unit.
- For single bed dwellings and flats/apartments in town centres, 1 space per unit will be required.
- For shared car parking provision an element of car park provision for disabled people will be required. Further details have been specified in Appendix 10, on page 181 within the draft RUDP.

Sheltered Housing Development

- For any sheltered housing proposals 1 space will be required per 3 units.

The UDP can be viewed and downloaded from the council's web site at www.wigan.gov.uk/pub/planning/pages/spd.htm and is available at our offices at the Planning and Regeneration Department.

Materials and building detailing

Careful consideration must be given to the choice of materials, both in terms of their colour and texture, in order to enhance and respond to the building characteristics of the area and to help enhance the overall appearance of the street.

Capturing views, creating focal points and vistas

Depending on the location of the site, any development should aim to maximise the long and short views into and out of the site to ensure visual links that connect to the wider area. Views into and out of the development can also help to create further visual guidance.

For medium to large-scale developments, being able to easily understand and find your own way around and through the development is essential. Existing distinctive landscaping, local landmarks, buildings and main routes should be used as focal points to help residents and visitors to easily position and direct themselves through and around an area. New focal points could include new buildings, public art or significant landscape elements.

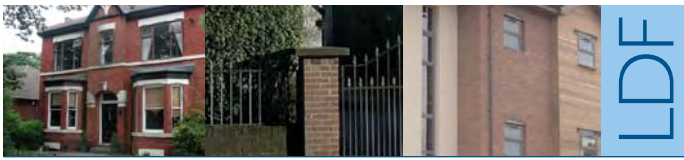

Landscaping

The provision of public open spaces and landscape features must be seen as an integral part of any development that is accessible to all.

- Any development must not result in any significant loss of important habitats or vegetation species.
- Plant heights should not restrict significant views

Any existing mature trees and/or landscaping should be maintained and incorporated into the development scheme in such a way that their long-term survival can be assured.

Taking into consideration the depth of root and height growths of some trees and shrubs, the location of any new trees and planting must avoid any underground and overhead utility services.

Any additional trees and planting along the site boundaries should aim to provide all year coverage, with a mixture of evergreen and deciduous species.

Public open spaces

For large to medium sized developments a comprehensive landscaping scheme must be devised. The provision of a large public open space would remove the need for smaller incidental spaces and is normally preferred.

New housing developments of 100 units or more must provide both large and smaller areas of public open space that link into a network of connected spaces and routes, in order to facilitate the movement of local species of animals and plants.

The ownership, function and maintenance responsibility of all outdoor spaces must be clearly defined.

Other outdoor amenity spaces

Private individual gardens

All houses should have an enclosed private garden of a reasonable size.

Where possible gardens should be large enough to accommodate mature trees and planting and provide private sitting-out area not overlooked by others.

Private communal gardens

It is the Council's aim to ensure a high-quality, outdoor usable space is provided.

High density development should have access to a landscaped space and where possible, ground floor occupiers should have an enclosed private garden. For other remaining residents the garden provision may include a communal garden.

Any unusable spaces between car parks, roads and buildings will not be considered as part of the communal garden provision.

Communal gardens must be screened and secured from parking areas, public roads and footpaths and an on-going landscape maintenance programme should be adopted.

In order to ensure long-term landscape maintenance and management is delivered, financial contributions have to be arranged at the earliest opportunity.



The Council has prepared two SPD's on,

- **Landscape design submissions, and**
- **Provision of open space in new housing developments, adoptions and financial contributions from developers**

Copies of the SPDs can be viewed and downloaded from the council's web site at www.wigan.gov.uk/pub/planning/pages/spd.htm or can be purchased for a small fee from the Planning and Regeneration Department office. Please refer to Appendix A for contact details.

Bicycle stores

All bicycle storage provision should be covered, secured, well lit and easily accessible to residents. For bicycle provision for apartment blocks please refer to page 22.

Bin stores

Careful consideration should be paid to the location of bins as every development will be expected to provide sufficient space for separate storage facilities for recyclable and non-recyclable waste.

Where communal bin stores are provided they should be secure and covered, with easy access for residents and collection agents.

For high-density developments the provision of Eurobins with a capacity of 1000 litres for domestic waste must be used on the basis of 8 residential units to one bin.

Biodiversity

Depending on the location of the site there may be a requirement to carry out ecological surveys, however some surveys can only be carried out at specific times of the year. The surveys will need to be submitted as part of the planning application and therefore consultation is needed at an early stage to avoid significant delays. Applications submitted without the required survey information are unlikely to be approved.

In order to provide opportunities to enhance biodiversity, any informal outdoor spaces should make use of existing features and where appropriate provide new natural features that will contribute to Wigan's biodiversity.

A number of case studies demonstrating the possibilities can be seen within the publication, Biodiversity by Design, copies of which can be obtained free from the Town and Country Planning Association, details of which can be found in Appendix A.

For further information on the borough's biodiversity issues please refer to Wigan's Biodiversity Strategy. The strategy can be viewed and downloaded from the council's web site at <http://www.wigan.gov.uk> or is available from the Environmental Services Department office. Please refer to Appendix A for contact details.

Boundary treatments

Boundary treatments have a number of purposes, for example they:

- help to define space,
- provide security,
- create a link between the buildings and landscape,
- provide a barrier between private and public uses, and
- influence the microclimate depending upon the type of treatment.

There are a number of different treatments and these can be divided into six characteristics;



See through boundaries: aid good views both through and over the development and provide safety, for example railings, trellis and decorative screens.



Solid boundaries: can be extensions to buildings and contribute to the streetscape, for example brick walls, timber fences, hedges and stone walls.



Combinations: Designing in a combination of solid and see through elements can enrich boundaries.

Natural boundaries: Carefully designed earth mounds, when accompanied by well designed planting schemes can provide an environmentally friendly means of screening.

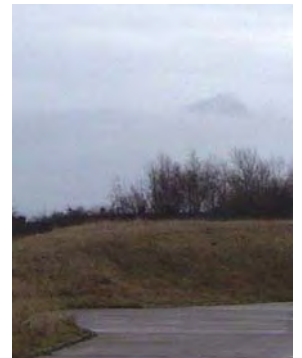

Hedges: A dense yet ecologically diverse boundary can be achieved by the use of a screen created by native plants

Water: Watercourses for example a river or canal can be used to help define a boundary edge.



The choice of boundary treatments should be appropriate to their surroundings. All of these different types of boundary treatments can easily be adapted to reflect the character of the development and area.

Please refer to the Council's SPD on The Good Fencing Guide for further advice, which is available on our web site at www.wigan.gov.uk/pub/planning/pages/spd.htm.



Provision of public art

We would encourage the provision of public art where appropriate within the design of the environment. Public art works can be used to reinforce the local identity of a place and can be used as a tool to help create a memorable place.

As a council we strongly support community driven projects, in conjunction with the developer and the use of local artists or groups. Whatever the scale and type of project we would advise early artist and community involvement within the design process.

Energy and water conservation

Developments should be designed and built from long lasting materials and have energy and water efficient household appliances installed to further encourage energy conservation and keep pollution to a minimum.

- Where appropriate, an investigation should be undertaken to determine whether any of the buildings or materials could be reused and recycled.
- The basic fitting out of the development before the point of sale should include energy and water efficient appliances.
- Any new materials should be from sustainable sources and where appropriate supplied by local manufacturers.

The design of the site layout and positioning of the buildings should maximise solar heat gain and natural daylight in order to minimise the consumption of conventional fuels.

Determining the position of housing to maximise solar gain whilst avoiding overheating is a complex process. For medium to large-scale developments we advise that there are a number of specialist computer simulation software available that can help to determine the most appropriate layout solution.

Crime prevention and community safety

The following points have been taken from the Office of the Deputy Prime Minister and Home Office publication, **Safer Places: The Planning System and Crime Prevention, 2004.**

Access and movement

An integrated network of clearly defined routes with easily recognisable points of entry should be achieved.

All outdoor spaces, for example car/ motorcycle/ cycle parking areas, public spaces and movement routes should be designed and illuminated to create a safe and secure environment and to minimise the opportunities for crime.

All routes should provide direct access to local facilities and houses.

Removing vulnerable routes and spaces from existing developments can reduce the opportunity for crime.

It is desirable to restrict public access to the rear of buildings. In particular secluded footpaths or alleyways should not run along the rear of buildings or provide access to buildings or gardens.

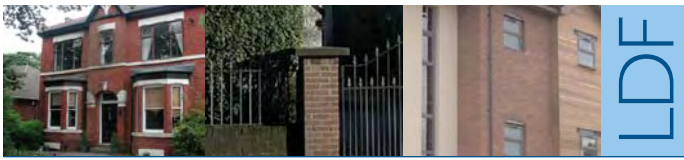

Structure

The design of developments should pay regard to the risk and fear of crime, and aim to create a safe, healthy and secure environment for both people and property.

Safe and sustainable places should be robust enough to cope with changing requirements or be flexible enough to evolve. Crime prevention should be 'planned in' to developments from the outset.

Surveillance

The layout and design of the development must maximise opportunities to overlook streets, car parking areas and any public spaces throughout the day and evenings, whilst ensuring privacy levels are maintained via reducing overlooking issues.

The design of any building/s should allow windows and doors to face onto the street to create 'active frontages' that allow overlooking opportunities to occur.

The main entrance to the property should not be screened from general view. Its location should be visible from windows within the house to aid in the identification of callers.

Any lighting scheme should be designed to avoid the occurrence of pools of darkness whilst ensuring that light pollution is reduced.

Ownership

Encouraging residents and users of places to feel a sense of ownership and responsibility for their surroundings can make an important contribution to crime prevention. This can be facilitated by clarifying where public space ends and where

communal, semi-private or private spaces begin. Uncertainty of ownership can reduce responsibility and increase the likelihood of crime and anti-social behaviour going unchallenged.

Involving residents and users – including young people – in the management and design of their area provides a real sense of ownership.

Allowing neighbourhoods to express their identity can generate feelings of ownership and reduce crime.

Sensitive placement and appropriate selection of physical barriers – gates, fences, walls and hedges – create safe places that are also attractive.

Landscaping can be used to make places safer as well as more attractive, however careful consideration must also be paid to the location of landscaping details in order to avoid creating public areas that are concealed from view.

Physical Protection

Many security measures may be installed without compromising the quality of the local environment.

The Secured by Design initiative offers in-depth advice on physical protection as part of a broad approach to designing out crime. It also sets out technical standards for building security and is an essential part of the crime prevention toolkit.

Activity

Designs should consider crime prevention within residential areas and provide a range of housing types in terms of dwelling size, type, tenure and affordability in order to attract a mix of people of different ages, lifestyles and economic status.



FIVE

Case Studies

This SPD aims to achieve a balance between making full use of urban sites and protecting and enhancing the local character and identity of the built environment. In addition to the principles and considerations already covered in this SPD there are a number of specific detailed guidance points that are particularly relevant to certain types of residential developments.

The purpose of this section is to provide examples of three specific development types:

- Case study 1: Apartment Development**
- Case study 2: Infill development**
- Case study 3: One to one house replacement and plot sub-division**

These examples are based upon the previously mentioned key planning and design principles and design considerations.

Case study 1:

Apartment Development

Apartment blocks are a typical example of high-density developments.

Character and identity of the area

New apartment developments must avoid damaging the existing character of the street and area. For example:

- where the new development would result in the loss of existing building/s of local architecture and/or historic value, or
- where there would be a too great a concentration of similar development schemes on adjacent sites along the same stretch of the street.

Existing characteristics of a site

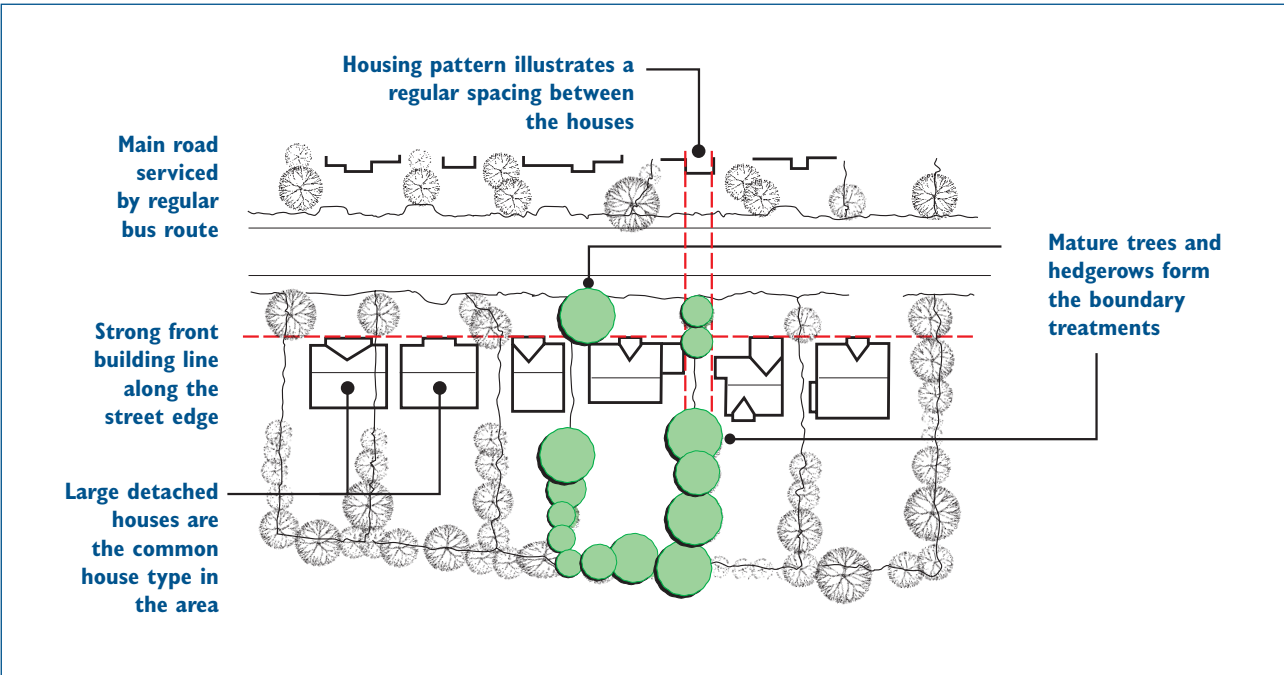

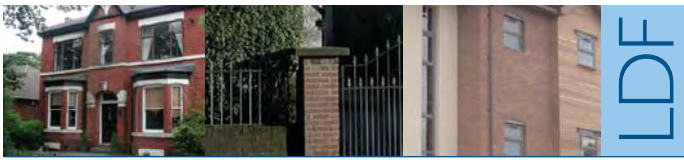

Height of development

Any developments must not be significantly higher than the existing adjacent properties. Exceptions to this rule are,

- when it is a corner site and there is the opportunity to provide a townscape feature.
- where existing mature trees that would be capable of being retained are in position along the site boundaries and already provide the site with a vertical scale.

Visual impact

The scale and massing of any development can be visibly reduced by variations in the depth and shape of the floor plans. An imaginatively designed floor plan (when worked up three dimensionally) allows the built form to be divided into recognisably smaller components that can be projected or set back in order to reduce the impact of a single large development. Indeed any development over two storeys, the use of the 'one box' design is unlikely to be acceptable on any site.

The design relationship between floor plans and proposed height of the development

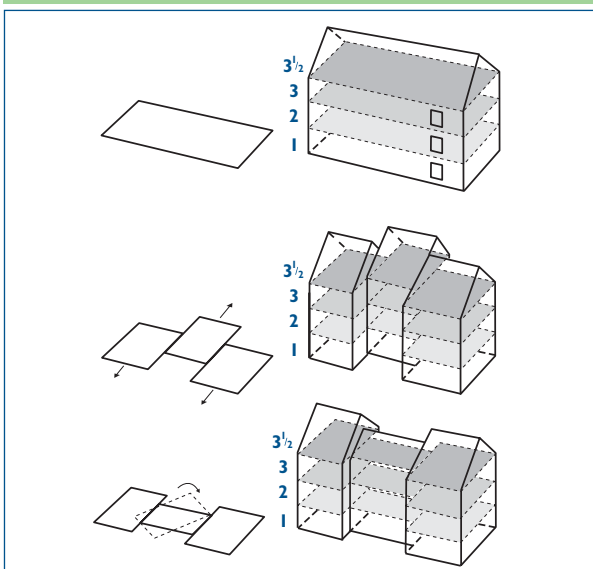

Provision of amenity space

People buying flats may still require some private outdoor space, and the use of roof gardens and balconies may be acceptable in appropriate locations. However it is important to exercise caution where issues of overlooking neighbouring properties may occur, for the opportunity for overlooking from a balcony or roof garden is significantly greater than that from a window. The council will therefore only support these elements where there is no detrimental impact on neighbouring plots.

Please be aware that the inclusions of balcony spaces do not count as part of meeting the requirements of the private outdoor amenity provision.

Private outdoor amenity space

The overall aim is to provide high quality outdoor amenity spaces which are usable.

Where possible, ground floor occupiers should have direct access on their own private space. For other remaining residents the outdoor amenity provision should include a communal garden.

Provision for ground floor occupiers

Ground floor residents should have their privacy protected. Appropriate buffers should be provided where possible, between the windows to ground floor flats and communal garden via the provision of private gardens/landscaping of a minimum depth of 3 metres.

Privacy for ground floor residents must be achieved, particularly on busy streets where the provision of a private space directly in front of windows cannot be adequately achieved. In these circumstances alternative solutions should be considered, for example raising the internal finished floor level above the street level.



Provision for a communal garden

For development up to two flats the size of the communal area should be based on a minimum area of 18 squared metres. For development comprising of more than two flats, an extra 5 squared metres should be provided for every additional flat.

Ground floor flats are excluded from the calculation as they must be treated separately. Please see 'provision for ground floor occupiers' as above for the details.

For example, if a development scheme consists of 16 flats, where 6 units on the ground floor, 6 units to the first floor and 4 units to the second floor the calculation would be,

Floor plan	No of flats (units)	Calculation	Total
Ground floor	6 units	Excluded from the calculation	0
First floor	6 units	2 units 4 units x 5m ²	18m ² 20m ²
Second floor	4 units	4 units x 5m ²	20m ²
Total min. space to be provided			58m ²

Bicycle parking provision

In accordance with policy A1S in the RUDP, whatever the scale of apartment development, 1 locker or other secure cycle storage space per unit is normally required.

Good example of the main elevation to an apartment development responding positively to the street scene



Case study 2:

Infill development

Before purchasing the land or devising any development plans you are advised to investigate whether there are any underground utility services.

There are two design approaches that can be undertaken for an infill development site.

One design approach is to replicate the existing design, detailing and style of the area in order to protect and enhance the existing character.

The second design approach acknowledges that it is not attempting to replicate the original character, and instead uses the existing design principles to formulate a contemporary and innovative design approach.

Where the second approach is taken there is scope to extend the design proposal, however this must be undertaken having considered the guidance already covered within this document and the following steps:

Any infill development should ensure:

- the established front and rear building lines are respected.
- any rhythm in the side spacing of buildings is repeated.
- infill developments respect the existing scale, massing and height.
- the materials are similar in nature, texture and colour to the existing buildings in the street scene.
- the windows should be similar in size, spacing and proportion to those on neighbouring homes. The location of windows on the

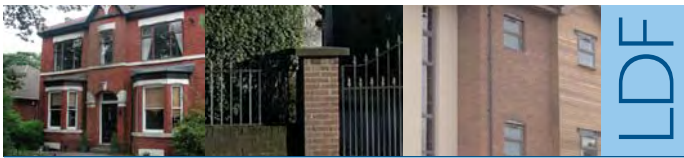

elevation (particularly the street elevation) is important to maintaining the architectural rhythm, patterns along the street.

- the roof design of new developments should reflect those of neighbouring properties.
- the front entry door of a new house should be placed on the main elevation.
- a degree of privacy is achieved and the issue of overshadowing is avoided.
- details and accessories such as gable and

eaves details, recessed window and doorframes are small but important details that contribute to the character of the neighbourhood.

- adequate access is provided from the public highway and car parking is an integral part of the design.
- where appropriate existing landscape features are maintained and any new landscaping are designed to enhance the scheme.

Infill development case study

Existing situation

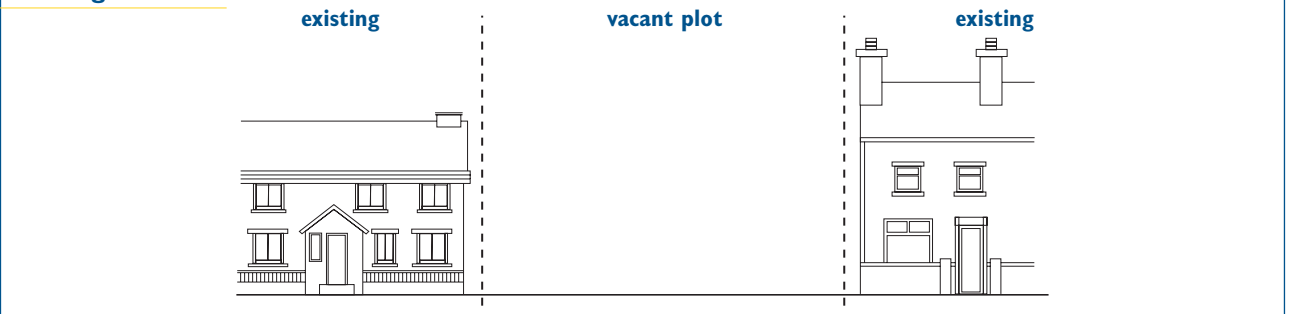

Example 1



Example 2

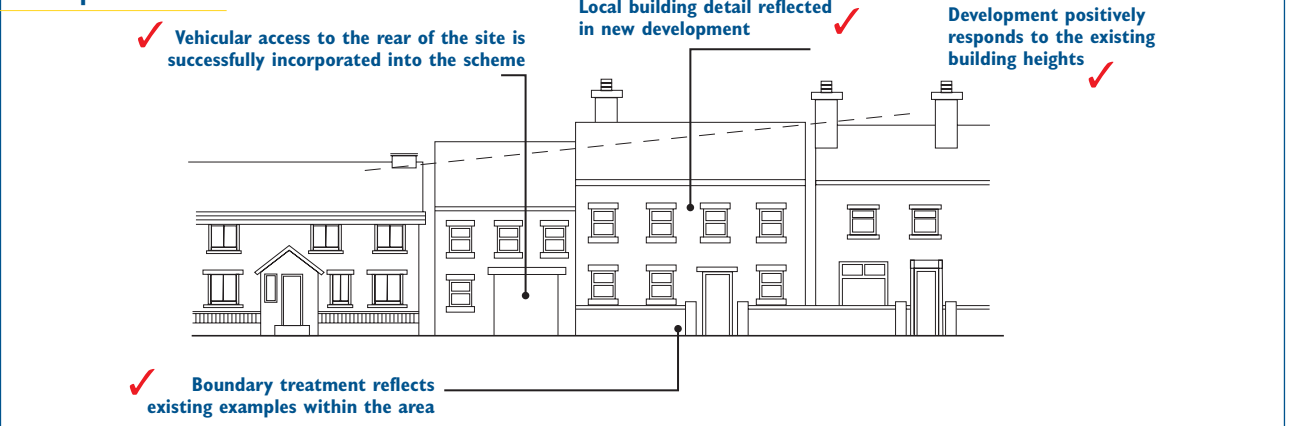



Case study 3:

One to one house replacement and plot sub-division

The cumulative effects of demolition and replacement upon the character of the area are important within established residential areas.

Any replacement should make reference to the demolished building or to the surrounding buildings in the streetscene, examples of which could be the established building line and frontage widths. However any increase in the footprint will be considered against the quality of the design in its context.

It is important that any developments are sensitively designed to minimise their impact upon the neighbouring properties and landscape. Landscaping issues may include the protection of existing mature trees and hedgerows.

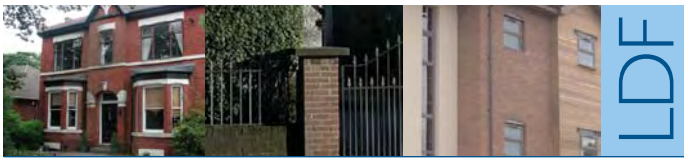

APPENDIX A

Access to information and contact details

We have the following means of access to planning information in place, which take into account issues of equality and diversity among the community.

- All documentation published by the council will be made available in electronic and paper format.
- To assist people with particular needs, many of our documents can be made available in large print, Braille, audiotapes and in a number of alternative languages on request.
- Copies of all documents produced by us will be made available to view at all of the local libraries in the borough, including the three mobile libraries; Wigan and Leigh Town Halls; and the Environmental Services Department offices at Civic Buildings, New Market Street, Wigan and Gateway House, Standishgate, Wigan. The opening times will vary for these locations and you are advised to check them first.
- If you have difficulty getting to any of the above locations, then the home library service may be able to bring documents to you on request. However, you must be registered with this service first. For further information you can phone the home library service on 01942 486985.
- Copies of this document and all other Supplementary Planning Documents that

have been quoted in this document can be purchased for a small fee, currently £5.00 (plus £1.00 postage).

Amounts will be subject to change so you are advised to check first.

You can contact us in the following ways:

If you require copies of documents please contact:

Implementation administration

Telephone 01942 404250

Other means of contacting the Implementation administration

email

environmentalservices@wigan.gov.uk

Facsimile 01942 404222

Letter

Implementation Section, Environmental Services Department, Wigan Council, Civic Buildings, New Market Street, Wigan, WN1 1RP

If you have any questions or need further advice or information about dealing with planning applications, or if you want to arrange a pre-application discussion please contact:

Development Control - West of the Borough

Wigan

Telephone 01942 488045



Orrell, Billinge, Winstanley, Bryn and Ashton-in-Makerfield

Telephone 01942 404275

Shevington, Standish and Aspull

Telephone 01942 404274

Development Control - East of the Borough

Hindley, Abram, Platt Bridge, Atherton, Tyldesley and Astley

Telephone 01942 404261

Leigh, Golborne and Lowton

Telephone 01942 404264

Other means of contact for all planning control matters

Facsimile 01942 404222

Email

devcon@wigan.gov.uk

Letter Development Control, Environmental Services Department, Wigan Council, Civic Buildings, New Market Street, Wigan, WN1 1RP

Building Control Service

For advice on structural issues and Building Regulations, please contact:

Telephone 01942 404227

Facsimile 01942 404222

Letter Wigan Council, Environmental Services Department, Building Control Section, Civic Buildings, New Market Street, Wigan, WN1 1RP

For other specialist planning advice please contact the following teams:

- **Conservation issues**

For advice on conservation matters

Telephone 01942 404254
or 404253

- **Urban Design issues**

For advice on general design matters

Telephone 01942 404243

- **Access issues**

For further advice and guidance on access issues

Telephone 01942 404247

- **Ecology and nature conservation**

For further advice on ecological and nature conservation issues

Telephone 01942 404232

- **Trees and Landscape**

For further advice on tree and landscaping issues

Telephone 01942 404233

Other relevant external organisations and agencies

- **British Waterways**

For advice relating to sites located adjacent to and/or in the vicinity of waterways, please contact:

Letter

British Waterways, Waterside House, Waterside Drive, Wigan WN3 5AZ

Website address:

www.britishwaterways.co.uk

Telephone 01942 405700

Facsimile 01942 405710

- **Countryside Agency**

Countryside Agency have produced a number of publications for example, a Planning Position Statement on Sustainable Design and Construction, please contact:

Letter

The Countryside Agency, North West Region, 3rd Floor, Bridgewater House, Whitworth Street, Manchester, M1 6LT

Website address: www.countryside.gov.uk

Telephone 0161 237 1061

Facsimile 0161 237 1062

Email: info.northwest@countryside.gov.uk

- **Environment Agency**

For more information on flood risk assessments, watercourses and flood maps please contact:

Letter

Environment Agency, Appleton House, 430 Birchwood Boulevard, Warrington, Cheshire, WA3 7WD

Website address:

www.environment-agency.gov.uk

Telephone 01925 543359

Facsimile 01925 852260

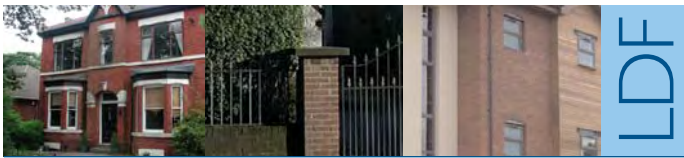

- **English Nature**

English Nature have produced a number of publications on ecological and nature conservation for further information please contact:

Letter

English Nature, Cheshire to Lancashire Team, Pier House, Wallgate, Wigan, WN3 4AL

Website address:

www.english-nature.org.uk

Telephone 01942 820342

Facsimile 01942 820364

- **Greater Manchester Fire and Rescue Service**

Advice regarding fire safety matters can be obtained from the:

Letter

Fire Safety (Enforcement) Department, Wigan Borough Command HQ, Wigan Fire Station, Robin Park Road, Wigan, WN5 0UU

Telephone 01942 650110

Facsimile 01942 650127

- **Greater Manchester Ecology Unit**

Letter

Greater Manchester Ecology Unit, Ryecroft Hall, Manchester Road, Audenshaw, Manchester M34 5ZL

Telephone 0161 371 9171

Facsimile 0161 371 8014

Email gmeu@tameside.gov.uk

- **Greater Manchester Passenger Transport Executive (GMPTE)**

GMPTE have produced a number of publications on access by, and design for public transport. If you would like to find out more information please contact:

Letter

9 Portland St, Piccadilly Gardens, Manchester, M60 1HX

By telephone: 0161 242 6000

By facsimile to: 0161 242 6057

Email: Landuse@gmpte.gov.uk

- **Greater Manchester Police Architectural Liaison Unit (GMP ALU)**

Early discussions with the GMP ALU are recommended before a planning application for residential is submitted.

Letter

GMP ALU, Divisional and Partnership Support Unit, PO Box 22 (S West PDO), Chester House, Boyer Street, Manchester, M16 0RE

Website address: www.gmp.police.uk

Telephone 0161 856 5912

Facsimile 0161 855 7489

Email:

architecturalliaisonunit@gmp.police.uk

- **Highways Agency**

Early discussions are welcome in particular where a development is located near to or would have an impact on the trunk road or motorway network.

Letter

Network Strategy, Highways Agency, Room 810, City Tower, Piccadilly Plaza, Manchester, M1 4BE

Website address: www.highways.gov.uk

Telephone: 0161 9305521

Email: spatialplanning@highways.gsi.gov.uk

- **Town and Country Planning Association (TCPA)**

For further advice and guidance on ecological, nature conservations and other planning issues please contact,

Letter

Town and Country Planning Association, 17 Carlton House Terrace, London, SW1Y 5AS

Website address: www.tcpa.org.uk

Telephone: 020 7930 8903

Facsimile: 020 7930 3280

- **United Utilities**

United Utilities have produced a Planning Application Guide and a number of other relevant publications to help with your planning application. If you would like to find out more information please contact:

Letter

United Utilities, Dawson House, Great Sankey, Warrington WA5 3LW

Telephone 01925 537 258

For all matters relating to the content of this SPD and related UDP, please **contact the**

Planning Policy Team:

Telephone 01942 404235/

404237/404238

Facsimile 01942 404222

Email

planningpolicy@wiganmbc.gov.uk

Letter

Planning Policy Team, Environmental Services Department, Wigan Council, Civic Buildings, New Market Street, Wigan, WN1 1RP



APPENDIX B

Planning policy context

National planning policies

The SPD has been prepared in the context of the Community Plan and has taken full account of national and regional policy and guidance, in particular PPG3. National planning policy is set out in Planning Policy Guidance notes (PPG's) and Circulars, which are gradually being replaced by Planning Policy Statements (PPS's). For the purpose of this SPD the most relevant national planning policies are,

- PPS 1 - Delivering Sustainable Development:** sets out guidance on the role of design considerations in planning, emphasising that good design is a key aim.
- PPG 2 - Green belts:** explains the purpose of including land in Green Belts and defines appropriate development within the Green Belt.
- (Draft) PPG 3 - Housing:** requires new developments to be of high quality. It advocates making the best use of the land we have available, and for new developments to be built in a sustainable way, sensitive to the needs of people and with consideration to their environmental impact.
- PPS 6 - Planning for Town Centres:** promotes town centre strategies based on urban design analysis, providing a
- PPS7 - Sustainable Development in Rural Areas:** environmental quality and economic and social development – promotes high standards of design and points to the role of Countryside Design Summaries, Village Design Statements and landscape character assessment.
- PPS9 - Biodiversity and Geological Conservation:** sets out planning policies on protection of biodiversity and geological conservation through the planning system.
- PPS 11 - Regional Spatial Strategies:** emphasises the importance of stakeholder involvement, sub-regional planning and co-ordination with other regional strategies including the Regional Housing Strategy.
- PPS 12 - Local Development Frameworks:** is a collection of documents setting out the council's planning policies that will guide the future development of the borough.
- PPG 13 - Transport:** requires new developments to help create places that are accessible by sustainable means of transport and which put people before

policy framework and the context for development briefs. It calls for improved standards for the design of street furniture, paving, signage and car parks.

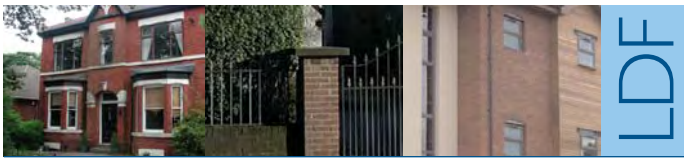

traffic, i.e. walking, cycling and the use of public transport.

creates a three-dimensional framework of buildings and public spaces (CABE 2004)

- **PPG 15 - Planning and the historic environment:** encourages detailed control of the external appearance of buildings in conservation areas, and emphasises the importance of how a building relates to its surroundings and of the quality of townscape.

- 'Safer Places: The Planning System and Crime Prevention' – (ODPM, 2004)

- **(Draft) PPG 25 - Development and flood risk:** explains that flood risk should be considered throughout the planning and development process, emphasising that management needs to be applied on a whole-catchment basis and not be restricted to flood plains.

Regional planning policies

The Interim draft revision Regional Spatial Strategy (RSS) for the North West of England continues to support the national policy on design and the efficient use of land on the basis that this can be achieved without compromising the quality of the environment. The draft RSS embraces the principle of sustainable patterns and forms of development in order to help our region realise a higher quality of life and improve economic prosperity.

In addition, a number of national planning and urban design guidance documents have been produced which, whilst not having statutory status, do nevertheless express the government's philosophy on the importance of design:

Local planning policies

The Unitary Development Plan (UDP) is the Council's statutory planning framework for the future development of the whole of the Borough. The advice provided in this SPD both supports and supplements the planning policies set out in the adopted and emerging draft Replacement Unitary Development Plan (UDP). **It is therefore essential to read this guide in conjunction with both sets of UDP planning policies in mind.**

- 'By Design' – a companion guide to PPG1 (DETR and CABE, 2000)
- 'Protecting Design Quality in Planning' - a guide for Planning authorities (CABE)
- 'Better Civic Buildings and Spaces' (CABE 2002)
- 'Better Places to Live: a companion guide to PPG3' (DTLR and CABE, 2001)
- 'Creating Successful Places Through Masterplanning' - the spatial masterplan



The Adopted UDP

The current RUDP was adopted in April 2006.

The relevant policies are:

- **EV2** Nature Conservation
- **EN2A** Special Areas of Conservation
- **EV2B** Sites of Special Scientific Interest, Sites of Biological Importance and Local Nature Reserves
- **EV2C** Features of Major Importance for Nature Conservation and Wildlife Corridors
- **EV2D** Species Protection
- **EV2E** Trees, Woodlands and Hedgerows
- **EV3** Design
- **EV3A** Design of New Development
- **EV3D** Landscaping of Development
- **EV4** Conservation
- **EV4A** Development and Design in Conservation Areas
- **EV4B** Listed Buildings
- **AIC** Access for People with Disabilities
- **RID** The Design of New Development and House Extensions

www.wigan.gov.uk or can be purchased for a fee from the Environmental Services Department office. Please refer to Appendix A for contact details.

A copy of the RUDP can be viewed and downloaded from the council's web site at

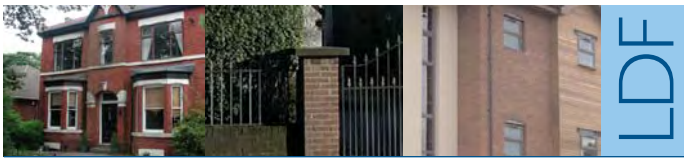

APPENDIX C

Planning application requirements

Before submitting a planning application the presence of existing underground and overhead utility services must be investigated.

In submitting any application the following information must be included as a minimum:

Clear scaled plans with the necessary existing and proposed dimensions including slab levels. The plans should include,

- Site surveys - Any housing schemes more than 1 unit must undertake a site survey, which will be included with the submission of the Design and Access Statement.
- Location Plan
- Details of existing site layout
- Details of proposed site layout
- Floor plans
- Elevations – showing the proposed ridge and eaves heights in relation to any neighbouring properties.
- Cross-sections

Additional information may also be required, depending upon the size of the development, its complexity and the sensitivity of its location.

This information could include:

- A Design and Access Statement
- Streetscene sketches – views of the pro-

posal from the surrounding area as seen by passers-by at street level

- Other supporting information
Depending upon the scale of the development scheme and the location of the site, further technical studies or site investigations may be required, for example

- Environmental Impact Assessment (EIA)
- Landscape and Visual Impact
- Ecology and protected species
- Land Contamination
- Transport Impact Assessment (TIA)
- Utilities Impact Assessment (UIA)
- Flood Risk Assessments

We therefore recommend that early consultation with the Environmental Services Department would help to determine the level of detail required.



APPENDIX D

Design and Access Statement

Purpose

PPS1 advocates that applicants should demonstrate how they have taken into account the need for good design and access issues in all planning applications.

A Design and Access Statement is a short report accompanying a planning application to illustrate the design process that has led to the development proposal and to explain and justify the proposed design in a structured way. It must relate directly to the individual site, the proposal being considered, the impact of the proposal on the wider area and how the overall scheme is designed out of crime. It may include, where appropriate, plans and elevations, photographs and illustrations. It is relevant for both outline and detailed applications.

The access aspect of the statement should indicate the applicant's approach to creating an accessible environment. The following offers further guidance on information that should be included in the statement to demonstrate a commitment to delivering high quality design standards and creating an accessible and inclusive environment.

Detail

This should include the site address, an accurate description of the development and the name of the applicant and agent.

The philosophy and approach

It should be shown that the design proposed has taken into account everyone's needs and has resulted in a development that can be used safely and easily by as many people as possible, without undue effort, separation or special treatment. An explanation of how the local context has influenced the design should be given.

What information and level of detail is required?

There is no set format for a statement but the level of detail will depend on upon the complexity of the proposal and the particular site. Generally, when submitting a statement the following points should be included as the minimum,

For the design aspects:

- 1 A list of the design principles and concept used for the scheme and how those principles meet the Council's own UDP policies and other relevant planning policies.
- 2 An outline of how the design principles and concept are reflected in the development's layout, use/s, density, scale, visual appearance and landscape.
- 3 Site surveys – These explain how the design relates to its site and wider area and the purpose of the proposed development.

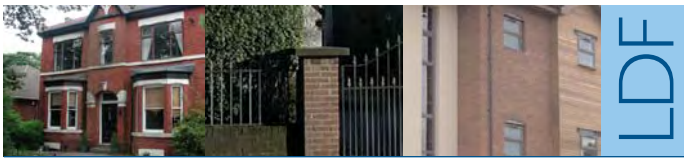

For specific access issues:

Evidence should be given that the position of the vehicular and pedestrian access into the site from the surrounding neighbourhood, and access and circulation routes within the site, take into account the needs of all users regardless of age, gender or disability.

It should be shown that dwellings have been designed, positioned and orientated within a site to achieve an accessible approach and entrance to them, and accessible routes from them to the surrounding area. Details should be given of the gradients, widths, surfaces, lighting, and the provision of dropped kerbs with tactile surfaces across the entrance and within the site.

Confirmation should be given that the principal entrance to each dwelling houses and entrance level flats/apartments will be accessible. The approach to entrances should preferably be level and if this is not possible ramped with the lowest possible gradient. A ramped approach must meet the requirements of the Building Regulations current at the time of the application. In exceptional circumstances on steeply sloping sites stepped approaches may be permitted.

It should be shown how any hard and soft landscaping will assist users to negotiate their way around the development, for example, choice of materials used on circulation routes and tactile surfaces to be used to warn of any changes in level.

Where site constraints affect compliance with the relevant design standards, an explanation of the constraints and standards that cannot be met should be included. It should give details of an

achievable alternative design proposal and indicate the level and standard of accessibility that this offers.

Connecting to the existing transport network

Details should be given of accessible routes from the existing transport network to the development.

The ability to reach a dwelling by car is important, so this should be taken into account for all dwellings. The distance and gradient from the car parking space to the dwelling should be given to show that these have been kept to a minimum.

Future maintenance

An explanation should be given of how features that ensure access to and around the development will be maintained. It should indicate procedures in place to ensure soft landscaping does not become overgrown and hence obstruct otherwise accessible routes.

Sources of access advice and consultation

Listed below are useful sources of information;

BS 8300:2001 "Design of buildings and their approaches to meet the needs of disabled people- Code of practice." BSI ISBN 0 580 38438 1

The Building Regulations 2000 Approved Document M Access to and use of buildings (2004 edition).

Department of Transport "Inclusive Mobility. A Guide to Best Practice on Access to Pedestrian and Transport Infrastructure"



The Design and Access Statement should include details of any professional advice that has been followed, consultation with any relevant officers and groups and how their comments have been taken into account.

Specific design and access advice needed for listed buildings

Where an application for listed building consent was involved the following points should be included in addition to achieving the above points;

A brief explanation of how design and access policies and approaches have taken account of paragraph 3.5 of PPG15 Planning and Historic Environment and in particular:

The historic and architectural importance of the building and its settings.

The particular physical features of the building and settings that justify its designation as a listed building.

A brief explanation of the range of access solutions considered, including an explanation of any specific issues affecting access to the listed building.

Contacts

If you would like to discuss any aspect of statement please refer to Appendix A on page 25 for our contacts for the design and access.

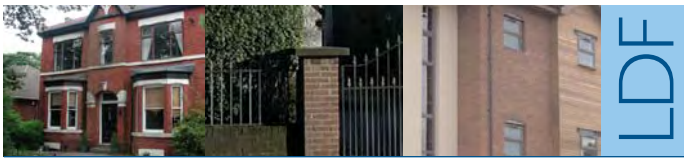

APPENDIX E

Building Control requirements

All new development must satisfy the following main criteria:

- 1 Have a principal entrance storey that is accessible and has adequate sanitary accommodation.
- 2 Have suitable foundations and an adequately robust building structure.
- 3 Have adequate resistance to the penetration of moisture and the effects of condensation.
- 4 Have adequate means of disposing of foul and surface water.
- 5 Be safe to live in with adequate stairs and guarding to landings, escape windows and where necessary safety glazing in critical locations, a smoke alarm system, adequate flues and hearths with appropriate information plates and a suitably designed, installed and tested electrical system.
- 6 The enclosure of the building, for example the walls, roofs, floors, doors and windows should be well insulated.
- 7 Have an efficient heating system with adequate control mechanisms and energy efficient lighting in an appropriate number of rooms.
- 8 Have adequate ventilation.
- 9 Have adequate resistance to the passage of sound.
- 10 Have adequate provision for the storage of solid waste.

LDF

WIGAN LOCAL DEVELOPMENT FRAMEWORK

Martin Kimber
Director of Environmental Services
Environmental Services Department
Civic Buildings, New Market Street, Wigan WN1 1RP



Environmental Services Department