

Building Control Guidance Leaflet 5

Conservatories and porches exempt from Building Regulations



Environmental Services Department

Conservatories

Under the 1991 Building Regulations, conservatories and porches which meet certain conditions do not require Building Regulation consent.

These conditions are that:

- 1 The floor area of the conservatory or porch must not be more than 30m² and the heating system of the existing dwelling is not extended into the conservatory or porch.
- 2 The walls and roof of a conservatory must be substantially glazed with transparent or translucent materials.
- 3 The conservatory or porch must be separated from the rest of the dwelling by a substantial door. For example, it cannot form part of a 'through room'.
- 4 The glazing in the conservatory or porch should meet the requirements for safety glazing. Safety glazing is explained below.

Requirements for safety glazing

The Building Regulations require that glazing in "critical" locations (see next section) must either:

- a break in a way unlikely to cause injury;
- b resist impact without breaking; or
- c be shielded or protected from impact.

Shielding must protect both the inside and outside of the glass. So, in practice it is most likely that toughened or laminated glass will be used in these locations.

Critical locations in internal and external walls

If any part of a pane is within 800mm of floor level, or within the 300mm either side of a doorway (to a height of 1500mm above floor level), it is said to be in a "critical" location and must meet the requirements for safety glazing. This is shown more clearly in the diagram. If any part of a pane falls within the shaded zones the whole pane must be of laminated or toughened glass. These panes are marked with a black spot (●).

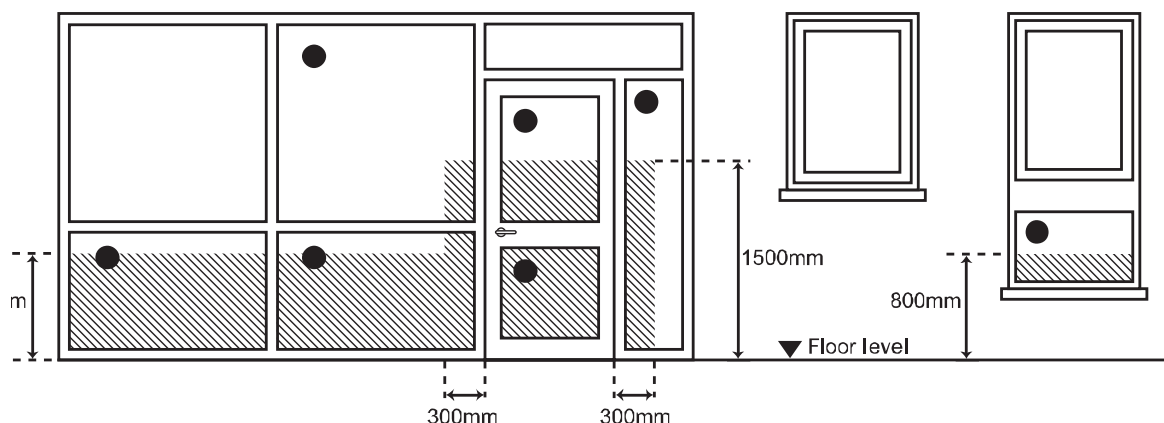

Other considerations

It is advisable to ensure that a conservatory does not restrict ladder access to any windows serving a loft conversion or a room in the roofspace. Such windows provide a means of escape in emergencies.

It should also be noted that additional approval may be required for any associated works to the house that you intend to carry out.

Whilst the structure of the conservatory may not need Building Regulation approval, certain controlled services and fittings that you might want in connection with it may need approval.

You may need to get Building Regulation approval if:

- You intend to alter or extend the drains serving the house.
- You want to install a toilet or sink unit for example.
- You intend to install a boiler in the building.

Also, any electrical installation in connection with the building must comply with Electrical safety requirement and an application may be required for that work.

Building Control

You are reminded that Building Regulations approval does not imply approval under the Town and Country Planning Act. You should always check whether or not a planning application is required.

This leaflet provides advice on a particular aspect of the Building Regulations. It is not a statement of law, but is intended to help you to understand the system.

Building Regulations are changed from time to time. If you did not receive this leaflet directly from Wigan Council's Environmental Services Department, you must check that the information is still current.

We are here to help. If you are in any doubt over the requirements of the Building Regulations, or if you need further information, please telephone or visit our office. Our details are:

**Wigan Council
Environmental Services Department
Building Control Section
Civic Buildings
New Market Street
Wigan WN1 1RP**

**Telephone: 01942 244991
Fax: 01942 404222
Website: www.wigan.gov.uk**

